

### 1MHz, High Efficiency, Flexible I<sup>2</sup>C Software program, 4 Internal MOSFETs Dual Buck DC-DC Converter

#### APPLICATION

- IoT (Internet of Things) Smart Home Appliance
- Mobile apps controllable DC source
- Automotive ADAS Power Supply
- LCD / Monitor Power Supply
- Wireless Router Power Supply
- Remote Power Management
  - Power Scheduler
  - CC-CV
- Low EMI Application (*Patent Pending*)

#### GENERAL DESCRIPTION

HT3828P is a high efficiency dual-channel, synchronous step-down switching converter designed for high-power dual-port DC-DC applications. It has a wide input range from 4.7V to 36 V, it supports wide range of output voltages, with typical output current of 1-2.5A per channel, up to 2-5A in total or higher, depending on applications. The Switching frequency is adjustable up to 1MHz by an external resistor to covers wide range of applications. Operating at high frequency reduces the size and cost of inductors and capacitors.

HT3828P has connection capability with wireless communication modules (e.g., Bluetooth/Wi-Fi) using the I<sup>2</sup>C serial interface. It can remotely control the ON/OFF, voltage and current limit of the HT3828P outputs.

HT3828P has soft start function that can prevent the inrush current at startup to protect the IC.

HT3828P has a variety of protection, such as input overvoltage protection, undervoltage protection, output over current protection, overvoltage, undervoltage, short circuit protection, and etc.

#### FEATURES

##### Internet of Things (IoT) Compatibility

- ON/OFF control
- Programmable using I<sup>2</sup>C serial interface
- Wireless connection with mobile apps

A sample IoT function is illustrated below flowchart:



##### Dual-Channel Synchronous Buck Converter

- Internal Power MOSFETs to save space
- Wide input voltage range: 4.7V to 36V
- Dual Channel with independent outputs
- Output current up to 3A at each channel
- Adjustable switching frequency up to 1MHz or beyond
- Support CC / CV mode
- The two channels are controlled independently
- Support USB Fast Charging applications
- Soft-start function

##### Multi-Protections

- Input under-voltage lockout (UVLO)
- Output over-voltage protection (OVP)
- Output short-circuit protection (SCP)
- Over-temperature protection (OTP)

##### Device Information

Part Number	Package	Shipping
HT3828P	5x5 QFN32	490 / tray

- See package outline and dimensions on p.11 of this datasheet.

## Typical Application Circuit

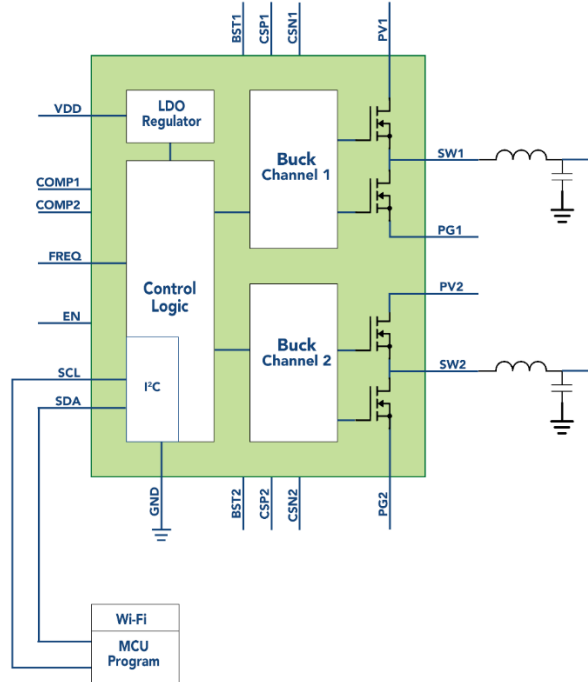

Fig. 1.1 - HT3828P Application Circuit

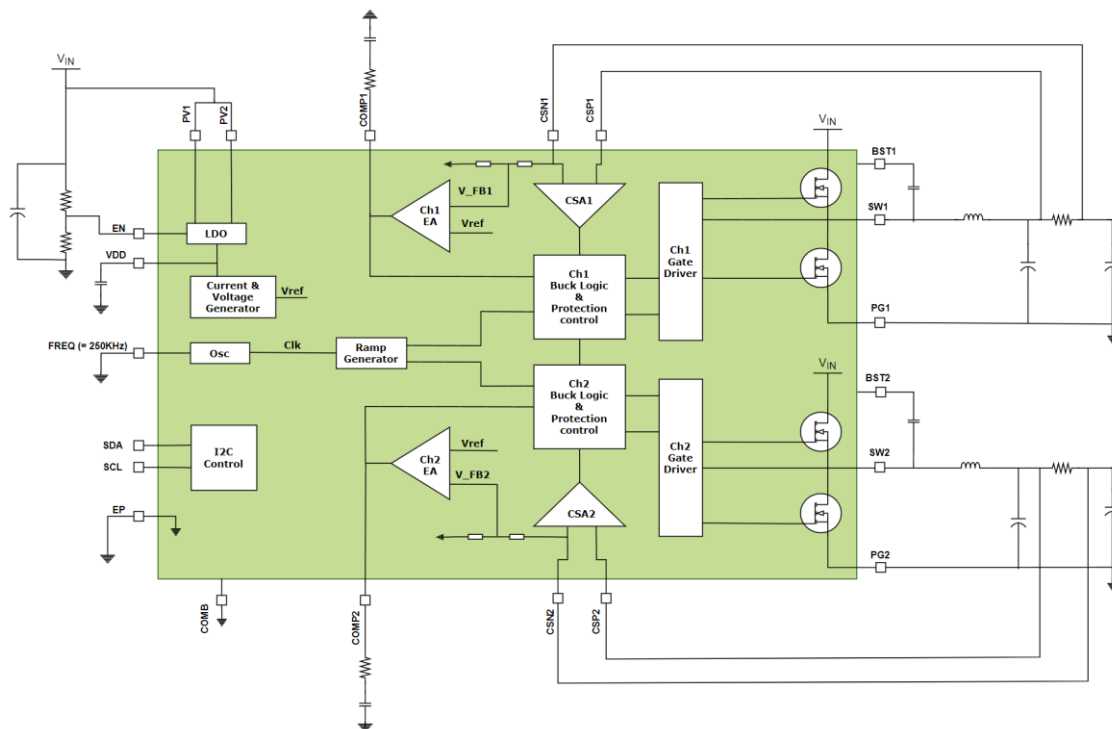

Fig. 1.2 - Detailed HT3828P Application Circuit

High Tech Technology Limited (HTT) reserves the right to make changes at any time, of any products or specifications herein, without further notice. HTT assumes no responsibility for the use of the information, nor does it assume any responsibility for any infringement of patents or other rights of third parties resulting from the use of the information. HTT does not grant any license under patent or patent rights, either implicitly or otherwise.

## Pin Configuration

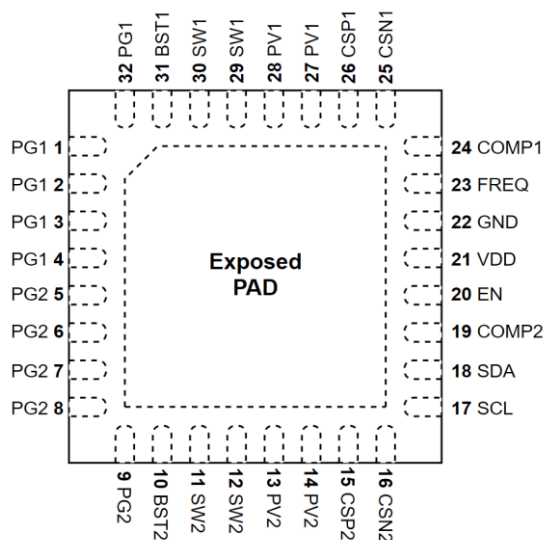

Fig. 2 - 32-pin QFN, 5x5 mm<sup>2</sup>, 0.5mm pitch TOP VIEW

## Pin Descriptions

Pin	Name	Description
1,2,3,4, 32	PG1	Power Ground Channel 1
5,6,7,8,9	PG2	Power Ground Channel 2
10	BST2	Bootstrap Channel 2. Connect a capacitor and a resistor to SW2. Recommend 0.1uF and 2Ω.
11, 12	SW2	Inductor Connection Channel 2
13, 14	PV2	Input Power Channel 2. Connect a capacitor to GND. Recommend 1uF.
15	CSP2	Current Sense Positive Channel 2
16	CSN2	Current Sense Negative Channel 2
17	SCL	I <sup>2</sup> C – Serial Clock Line
18	SDA	I <sup>2</sup> C – Serial Data Line
19	COMP2	Compensation Pin 2
20	EN	Chip Enable, 1.35V enables the device
21	VDD	VDD Regulator, connect a decoupling capacitor to GND. Recommended 2.2uF.
22	GND	Signal Ground
23	FREQ	Frequency Selection, See the Application Information Section for details.
24	COMP1	Compensation Pin 1
25	CSN1	Current Sense Negative Channel 1
26	CSP1	Current Sense Positive Channel 1
27, 28	PV1	Input Power Channel 1. Connect a capacitor to GND. Recommend 1uF.
29, 30	SW1	Inductor Connection Channel 1

## HT3828P (Preliminary)

31	BST1	Bootstrap Channel 1. Connect a capacitor and a resistor to SW1. Recommend 0.1uF and 2Ω.
33	EPAD	Signal Ground & Thermal Dissipation Pad

**3828P3828P Absolute Maximum Rating**

PV1, PV2, SW1, SW2, EN, BST1, BST2	-0.3V to 40V
HS_DRV1, LS_DRV1, HS_DRV2, LS_DRV2	-0.3V to 36V
CSP1, CSN1, CSP2, CSN2	-0.3V to 22V
VDD, COMP1, COMP2, FREQ, SCL, SDA	-0.3V to 6V
Operating Temperature Range	-40°C to 85°C
Maximum Junction Temperature	125°C
Storage Temperature Range	-65°C to 125°C
Soldering Temperature	300°C

**Electrical Characteristics**

Limits apply over the operating temperature range, unless else specified. Max and Min limits are provided through design, test or statistical dependence. Typical values are the most likely parametric norm at room temperature, and are stated for reference only. Unless specified the following conditions apply:  $V_{IN} = 12V$ ,  $T_A = 25^\circ C$ .

Parameters	Symbol	Test Conditions	Rating			Unit
			MIN	TYP	MAX	
<b>Input Characteristics</b>						
Input Voltage	$V_{IN}$		4.7		36	V
EN Threshold	$V_{EN}$			1.35		V
EN Hysteresis	$V_{ENHYS}$			110		mV
VDD regulator	$V_{REG}$			5.4		V
Quiescent current	$I_Q$	FREQ Pin Open		1.5		mA
<b>Output Characteristics</b>						
Output Voltage Range	$V_{OUT}$	$V_{IN}=24V$	3.3		20	V
Cycle by cycle Current Limit	$I_{OCP}$			3.6		A
<b>Switching Characteristics</b>						
High Side MOSFET Turn On Resistance	$R_{DS\_HS(ON)}$			100		mΩ
Low Side MOSFET Turn On Resistance	$R_{DS\_LS(ON)}$			100		mΩ
Switching Frequency	$f_{sw}$		350		1000	kHz
Minimum Off-Time	$t_{OFF, Min}$			50		ns
<b>Output control by PROG (For both channel1 and channel2)</b>						
Single Channel Output Voltage (PROG)	$V_{OUT\_PROG}$	DAC_CV = 0.5V		5		V
		DAC_CV = 0.9V		9		V
		DAC_CV = 1.2V		12		V
		$V_{IN}=24V$ , DAC_CV = 2V		20		V
	$V_{STEP\_PROG}$	DAC_CV step		100		mV
Single Channel Output Current (PROG)	$I_{OUT\_PROG}$	Rcs=10mΩ, DAC_CC = 1.2V		3		A
		Rcs=10mΩ, DAC_CC = 0.8V		2		A
		Rcs=10mΩ, DAC_CC = 0.6V		1.5		A
		Rcs=10mΩ, DAC_CC = 0.4V		1		A

## Electrical Characteristics

Limits apply over the operating temperature range, unless else specified. Max and Min limits are provided through design, test or statistical dependence. Typical values are the most likely parametric norm at room temperature, and are stated for reference only. Unless specified the following conditions apply:  $V_{IN} = 12V$ ,  $T_A = 25^\circ C$ .

Parameters	Symbol	Test Conditions	Rating			Unit
			MIN	TYP	MAX	
<b>I<sup>2</sup>C Interface</b>						
SCL Clock Frequency	$f_{SCL}$				400	kHz
Input Threshold High	$V_{(I2C\_TH\_H)}$	SDA, SCL		3.6		V
Input Threshold Low	$V_{(I2C\_TH\_L)}$	SDA, SCL		1		V
Output voltage Low	$V_{(I2C\_OL)}$	Isk=5mA into SDA, SCL			0.3	V
<b>Input Under-voltage Lockout</b>						
Input Under-Voltage Lockout Threshold High	$V_{UVLO}$			4.7		V
Input Under-Voltage Lockout Hysteresis	$V_{UVHYS}$		0.53	0.64	0.71	V
<b>Output Under-voltage Lockout</b>						
Output Under-voltage Protection	$V_{UVP}$			$V_{FB} * 60\%$		V
<b>Output Over-voltage Protection</b>						
Output Over-Voltage Protection	$V_{OVP}$			$V_{FB} * 120\%$		V
<b>Over-Temperature Protection</b>						
Thermal Shutdown	$T_{SD}$	Increasing Temperature		140		$^\circ C$
Thermal Shutdown Hysteresis	$T_{SD\_HYS}$	Decreasing temperature		30		$^\circ C$

## Functional Block Diagram

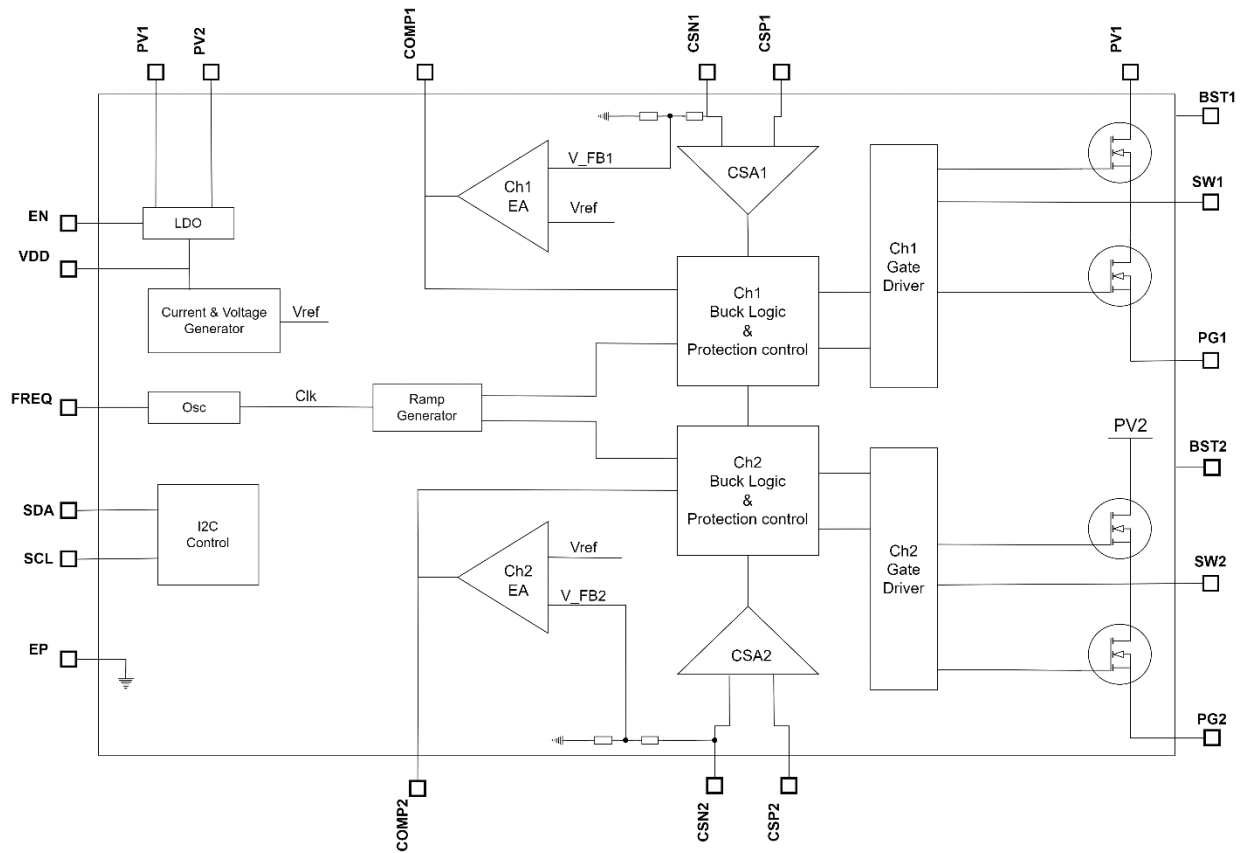

Fig. 3 – Functional Block Diagram

## Application Information

### Input Protection

If the input voltage is smaller than Input UVLO, both buck channels stop the gate driver, reset and enter hiccup mode. It returns to Normal when the faults are cleared.

### Output Protection

The Output Under-voltage Lockout threshold and the Output Over-voltage Protection are set at  $V_{OUT} * 60\%$  and  $V_{OUT} * 120\%$ . Once Output UVLO or OVP is triggered, the specific channel stops the gate driver, reset and enter hiccup mode.

### Soft Start

HT3000 series employs an internal soft start in the buck converter to prevent large inrush current and overshoots of  $V_{OUT}$ . The soft start time is 20ms in the design.

### Frequency Selection

The switching frequency can be adjusted by an appropriate resistor connected to the pin FREQ. The efficiency of the conversion depends on the switching FET. The efficiency is usually slightly higher at lower frequency because of the lower switching loss.

### Programmable Output by I<sup>2</sup>C Serial Interface

A wireless communication module such as ESP8266 (master) can access HT3828P (slave) internal registers through the SCL and SDA pins. The master can program HT3828P power output by writing hex data to the registers. This I<sup>2</sup>C serial interface is enabled by setting the EN pins voltage greater than 8V ( $\max V_{EN} = 36V$ ).

### Constant Voltage / Constant Current Mode

HT3828P has the capability to operate in either CV (constant voltage) mode or CC (constant current) mode, with a smooth transition from CV to CC (See Fig.4). When in CV mode, it regulates the output voltage. Once the output current limit threshold is reached, HT3828P switches to CC mode. In CC mode, the output voltage decreases while the output current remains clamped at the predefined values. The current limit can be determined using the following equation.

$$I_{out(max)} = \frac{36mV}{R_{sense}}$$

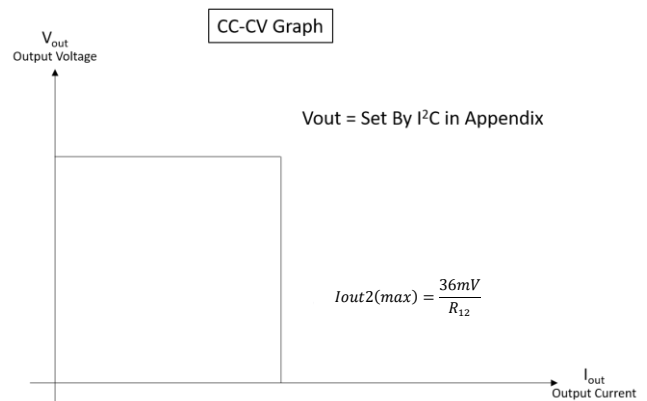

Fig.4 CC-CV graph

Typical operating characteristics at switching frequency 350kHz

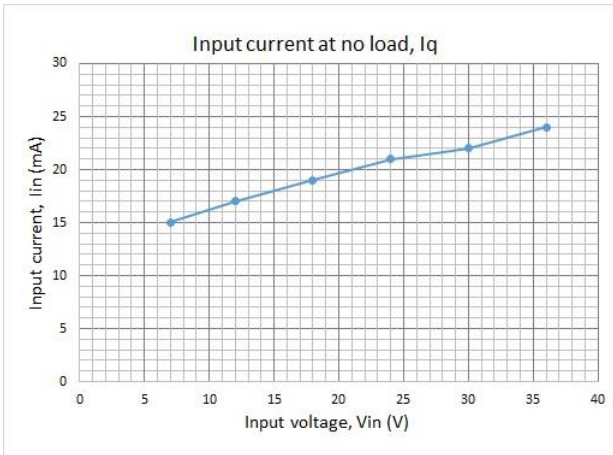

Fig. 5 Quiescent current vs input voltage

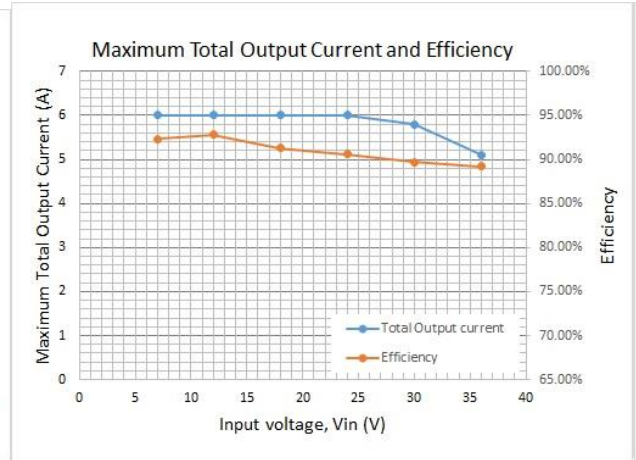

Fig. 6 Maximum total current and efficiency at CV mode output 5V

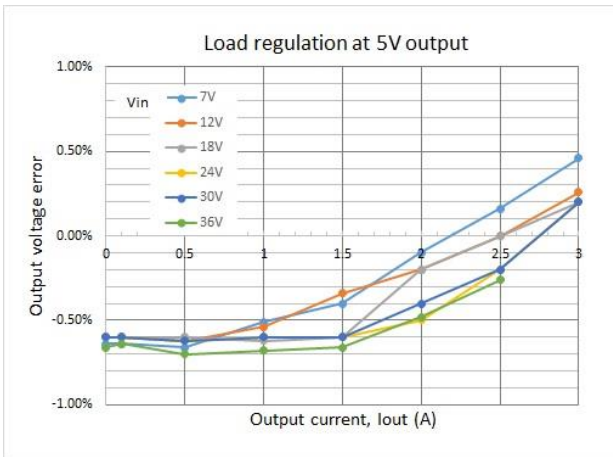

Fig. 7 Load regulation at CV mode output 5V

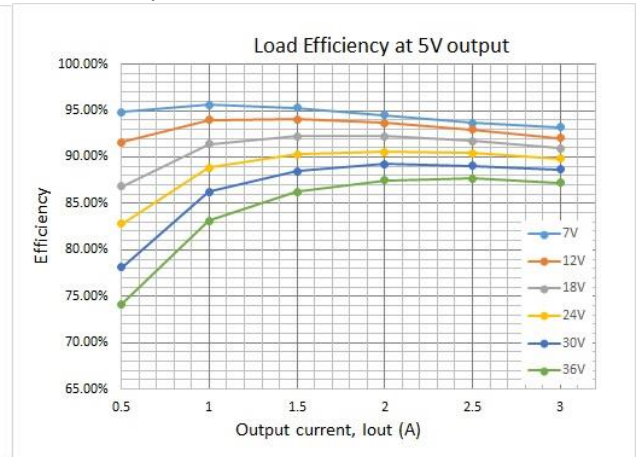

Fig. 8 Load efficiency at CV mode output 5V

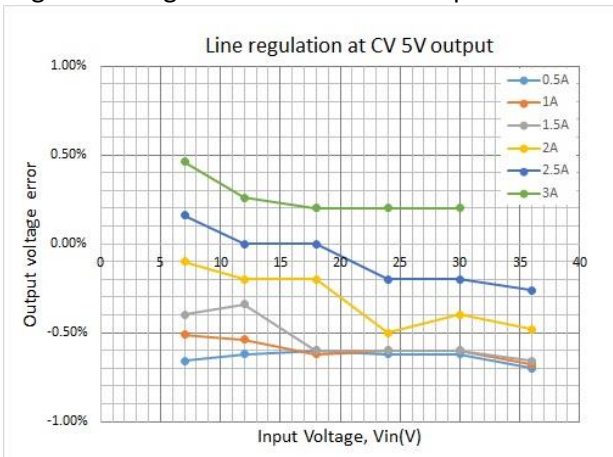

Fig. 9 Line regulation at CV mode output 5V

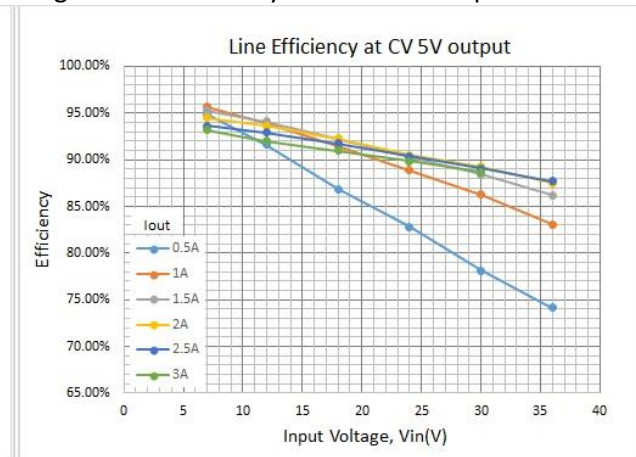

Fig. 10 Line efficiency at CV mode output 5V

# HT3828P (Preliminary)

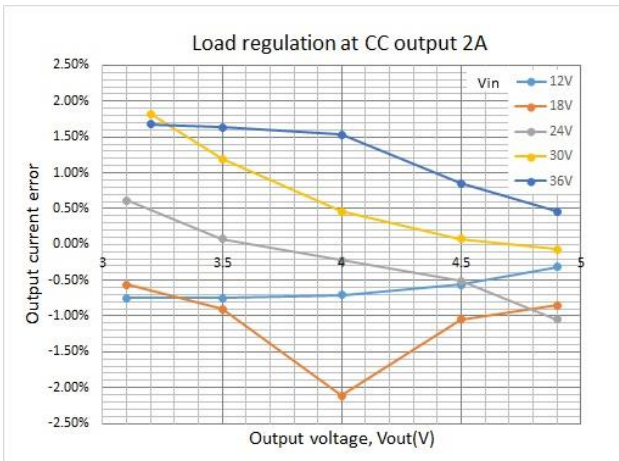

Fig. 11 Load regulation at CC mode output 2A

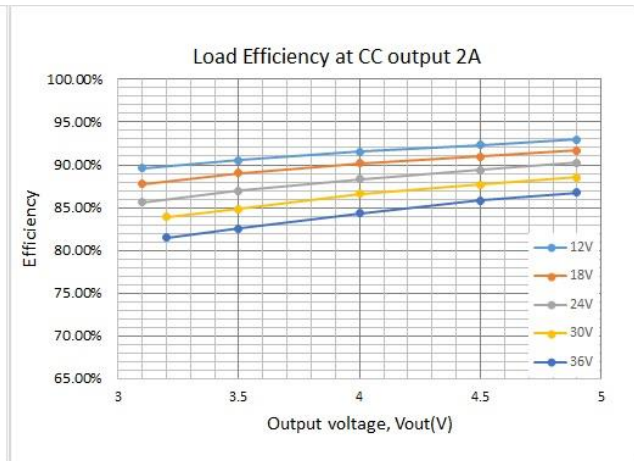

Fig. 12 Load efficiency at CC mode output 2A

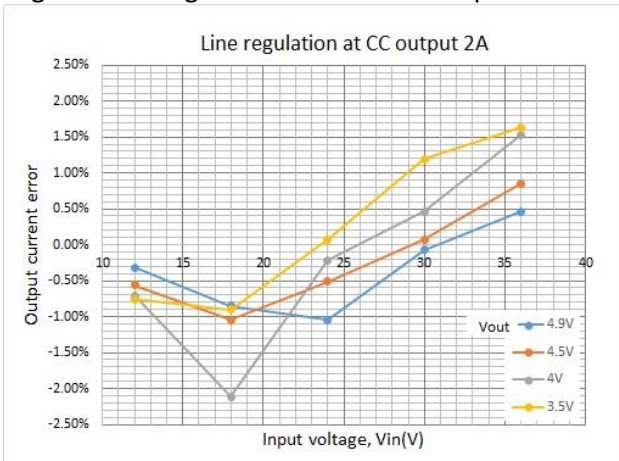

Fig. 13 Line regulation at CC mode output 2A

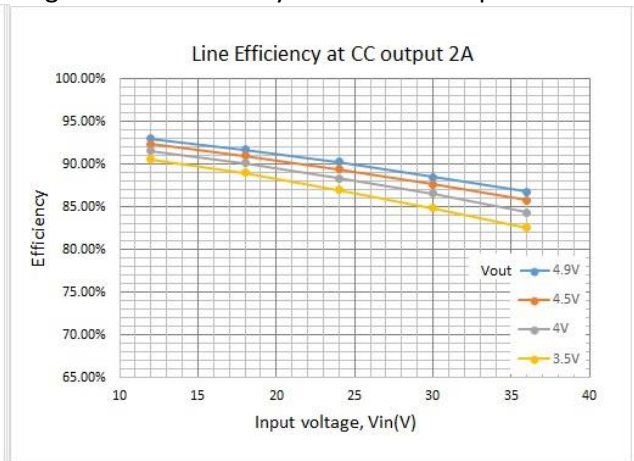

Fig. 14 Line efficiency at CC mode output 2A

**Typical Application Circuit**

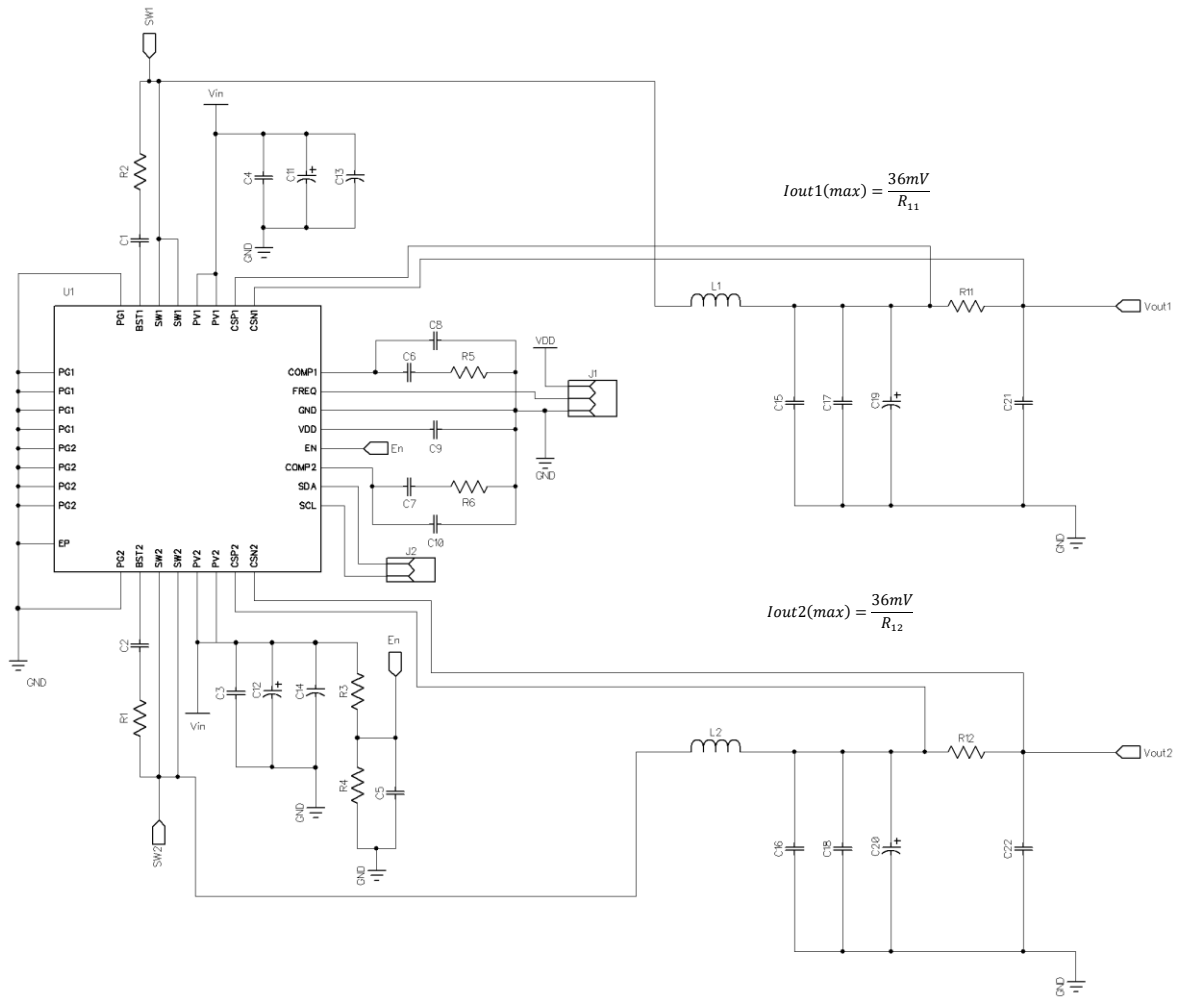
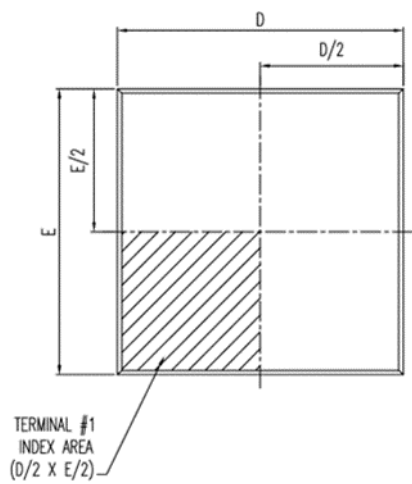

Fig. 15 – HT3828P simplified Application Schematic

# HT3828P (Preliminary)

## Package Outline and Dimensions



Top View

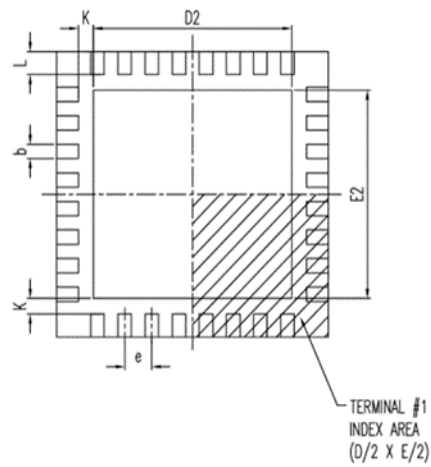

Bottom

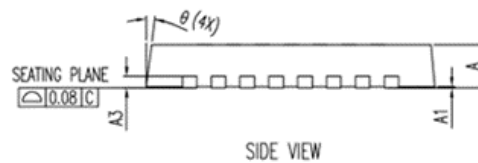

Side View

SYMBOL	DIMENSION IN MM		
	MIN.	NOM.	MAX.
A	0.70	0.75	0.80
A1	0	0.02	0.05
A3	0.20 REF.		
D	5.00 BASIC		
D2	3.50	3.65	3.80
E	5.00 BASIC		
E2	3.50	3.65	3.80
e	0.50 BASIC		
b	0.18	0.25	0.30
L	0.35	0.40	0.45
K	0.20		
θ	0°		14°
JEDEC	MO-220 (Variation WHHD-4)		

- NOTES :
1. ALL DIMENSIONS ARE IN MILLIMETERS.
  2. DIMENSION b APPLIES TO METALLIZED TERMINAL AND IS MEASURED BETWEEN 0.15mm AND 0.30mm FROM THE TERMINAL TIP. IF THE TERMINAL HAS THE OPTIONAL RADIUS ON THE OTHER END OF THE TERMINAL, THE DIMENSION b SHOULD NOT BE MEASURED IN THAT RADIUS AREA.
  3. BILATERAL COPLANARITY ZONE APPLIES TO THE EXPOSED HEAT SINK SLUG AS WELL AS THE TERMINALS.

Fig. 17 32-pin QFN, 5mm x 5mm, 0.5mm pitch

## HT3828P (Preliminary)

### Appendix

The hex data values for programmable constant voltage (CV). The lowest value of CV (output voltage) may go down to 1.2V, depending on applications. The step size is 100mV.

I2C Data (Hex)	CV (V)	I2C Data (Hex)	CV (V)	I2C Data (Hex)	CV (V)	I2C Data (Hex)	CV (V)	I2C Data (Hex)	CV (V)	I2C Data (Hex)	CV (V)
20	3.2	40	6.4	60	9.6	80	12.8	A0	16.0	C0	19.2
21	3.3	41	6.5	61	9.7	81	12.9	A1	16.1	C1	19.3
22	3.4	42	6.6	62	9.8	82	13.0	A2	16.2	C2	19.4
23	3.5	43	6.7	63	9.9	83	13.1	A3	16.3	C3	19.5
24	3.6	44	6.8	64	10.0	84	13.2	A4	16.4	C4	19.6
25	3.7	45	6.9	65	10.1	85	13.3	A5	16.5	C5	19.7
26	3.8	46	7.0	66	10.2	86	13.4	A6	16.6	C6	19.8
27	3.9	47	7.1	67	10.3	87	13.5	A7	16.7	C7	19.9
28	4.0	48	7.2	68	10.4	88	13.6	A8	16.8	C8	20.0
29	4.1	49	7.3	69	10.5	89	13.7	A9	16.9	C9	20.1
2A	4.2	4A	7.4	6A	10.6	8A	13.8	AA	17.0	CA	20.2
2B	4.3	4B	7.5	6B	10.7	8B	13.9	AB	17.1	CB	20.3
2C	4.4	4C	7.6	6C	10.8	8C	14.0	AC	17.2	CC	20.4
2D	4.5	4D	7.7	6D	10.9	8D	14.1	AD	17.3	CD	20.5
2E	4.6	4E	7.8	6E	11.0	8E	14.2	AE	17.4	CE	20.6
2F	4.7	4F	7.9	6F	11.1	8F	14.3	AF	17.5	CF	20.7
30	4.8	50	8.0	70	11.2	90	14.4	B0	17.6	D0	20.8
31	4.9	51	8.1	71	11.3	91	14.5	B1	17.7	D1	20.9
32	5.0	52	8.2	72	11.4	92	14.6	B2	17.8	D2	21.0
33	5.1	53	8.3	73	11.5	93	14.7	B3	17.9		
34	5.2	54	8.4	74	11.6	94	14.8	B4	18.0		
35	5.3	55	8.5	75	11.7	95	14.9	B5	18.1		
36	5.4	56	8.6	76	11.8	96	15.0	B6	18.2		
37	5.5	57	8.7	77	11.9	97	15.1	B7	18.3		
38	5.6	58	8.8	78	12.0	98	15.2	B8	18.4		
39	5.7	59	8.9	79	12.1	99	15.3	B9	18.5		
3A	5.8	5A	9.0	7A	12.2	9A	15.4	BA	18.6		
3B	5.9	5B	9.1	7B	12.3	9B	15.5	BB	18.7		
3C	6.0	5C	9.2	7C	12.4	9C	15.6	BC	18.8		
3D	6.1	5D	9.3	7D	12.5	9D	15.7	BD	18.9		
3E	6.2	5E	9.4	7E	12.6	9E	15.8	BE	19.0		
3F	6.3	5F	9.5	7F	12.7	9F	15.9	BF	19.1		

The hex data values for programmable current limit (CC). The step size is 100mA. Rsense=10mΩ.

I2C Data (Hex)	CC (A)	I2C Data (Hex)	CC (A)	I2C Data (Hex)	CC (A)	I2C Data (Hex)	CC (A)	I2C Data (Hex)	CC (A)	I2C Data (Hex)	CC (A)
0	-	7	0.7	E	1.4	15	2.1	1C	2.8	23	3.5
1	0.1	8	0.8	F	1.5	16	2.2	1D	2.9	24	3.6
2	0.2	9	0.9	10	1.6	17	2.3	1E	3.0	25	3.7
3	0.3	A	1.0	11	1.7	18	2.4	1F	3.1	26	3.8
4	0.4	B	1.1	12	1.8	19	2.5	20	3.2	27	3.9
5	0.5	C	1.2	13	1.9	1A	2.6	21	3.3	28	4.0
6	0.6	D	1.3	14	2.0	1B	2.7	22	3.4		

High Tech Technology Limited (HTT) reserves the right to make changes at any time, of any products or specifications herein, without further notice. HTT assumes no responsibility for the use of the information, nor does it assume any responsibility for any infringement of patents or other rights of third parties resulting from the use of the information. HTT does not grant any license under patent or patent rights, either implicitly or otherwise.

## HT3000 Series

Smart Home Connection  
At Your Fingertips



Hong Kong Office

Tel: (852) 36195375

Email: [httadmin@hightt.com](mailto:httadmin@hightt.com)

URL: <https://hightt.com>

Address:

Unit 713, 7/F, 12W, 12 Science Park West Avenue,  
Hong Kong Science Park, Shatin, Hong Kong