

HT5530: USB-C PD 3.1 High-Voltage Low-Power RISC-V 140W Source (Power Giver) Controller

APPLICATIONS

- Power Giver
- Fast Travel/Car Chargers
- Note Book Computers

GENERAL DESCRIPTION

HT5530 is a highly integrated, low power consumption PD source controller designed for products with USB Type-C PD Source. It supports charging power up to 140W. HT5530 supports multiple PDOs with programmable voltage and current for different applications, such as PPS PDOs, EPR PDOs. All of PDOs are fully compliant with USB PD 3.1

HT5530 supports most DPDM charging protocols, such as QC2.0 or QC3.0 by configuring the DP and DM pins which provides excellent compatibility for the legacy devices.

HT5530 integrates a GATE driver to enable the VBUS from VIN to protect the devices connected with Type-C connector.

The high voltage tolerance and protections at CC1, CC2, DP and DM pins provide more reliability for the system.

HT5530 provides the smart power derating function for dual-port charger applications. With a 10-bit A/D converter, IC external temperature via an NTC resistor can be monitored.

HT5530 incorporates various protections, such as Under Voltage Protection (UVP), Over Voltage Protection (OVP), Over Current Protection (OCP), CC1 and CC2 Over Voltage Protection (CC_OVP), and internal Over Temperature protection (I_OTP).

FEATURES

- 32-bit, RISC-V microcontroller
- USB-C PD3.1
- Maximum charging power 140W
- 28V EPR FPDO, EPR AVS and PPS Supported
 - FPDO: 5V 3A, 9V 3A, 12V 3A, 15V 3A, 20V 5A
 - EPR FPDO: 28V 5A
 - EPR AVS: 15V - 28V 5A
 - PPS: 5V - 21V 5A
- Multiple DPDM Charging Protocols Implemented
 - Apple 5V, 2.4A mode
 - BC1.2 DCP mode
 - QC2.0 5V/9V/12V and 20V
 - QC3.0 3.6V~20V continuous model voltage mode with 200mV step adjustment
- Constant Voltage (CV) and Constant Current Limit (CC) Regulation
 - Integrated secondary side compensation circuit, such as TL431
- Built-in VIN and VBUS pins fast discharge scheme
- Small Current Sensing Resistor (5mΩ) for High Efficiency application
- CC1/CC2 Pin Protection up to 28V
- Support cable drop compensation with 0, 50m, 100m/200mΩ selection
- Support Smart Power Derating function at two ports USB application (USB-C or USB-A)
- Integrated VCONN Power for e-Marker Detection
- Sleep Mode Supported
- Low power consumption

DEVICE INFORMATION

Part Number	Package	Dimensions (mm)
HT5530	QFN16	4.0 x 4.0 x 0.75

TYPICAL APPLICATION

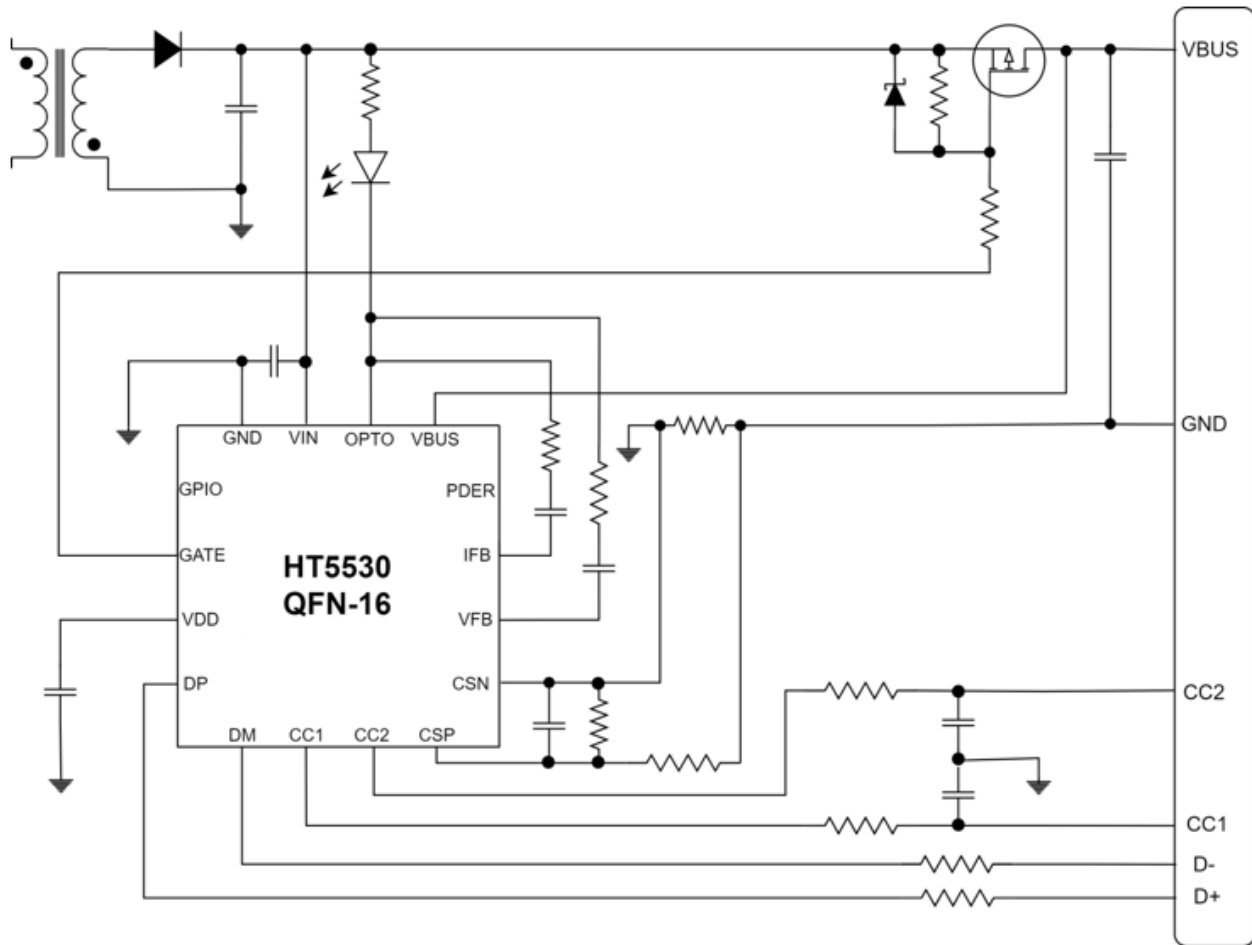

Figure 1. Typical Application Circuit of HT5530

PIN CONFIGURATION

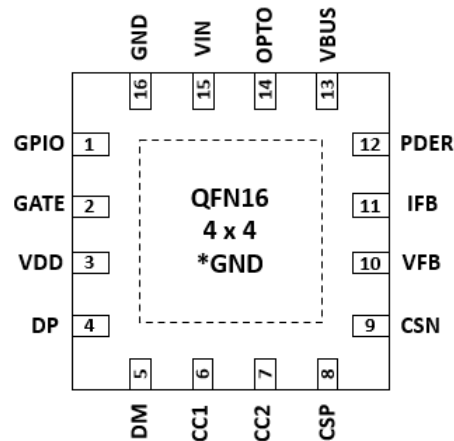

Figure 2. 16-pin DFN 4x4mm², (Top View)

Pin Functions

Pin No.	Pin Name	Pin Type	Voltage Type	Pin Description
1	GPIO	Open Drain IO	LV	General purpose IO
2	GATE	Open Drain IO	HV	Open drain gate driver to the gate of PMOS load switch
3	VDD	Supply	LV	Internal LDO output voltage. Connect this pin to GND via an 1uF ceramic capacitor
4	DP	Analog IO	HV	USB D+ line
5	DM	Analog IO	HV	USB D- line
6	CC1	Analog IO	HV	USB Type-C Configuration Channel1
7	CC2	Analog IO	HV	USB Type-C Configuration Channel2
8	CSP	Analog I	LV	Positive input of the current sense amplifier
9	CSN	Analog I	LV	Negative input of the current sense amplifier. Provide a low ohmic connection to GND
10	VFB	Analog I	LV	Voltage loop feedback & compensation.
11	IFB	Analog I	LV	Current loop feedback & compensation.
12	PDER	Analog I	LV	Power derating control pin. It is pulled high internally. Connect different resistors to GND to achieve power derating
13	VBUS	Analog I	HV	VBUS sense and discharge
14	OPTO	Analog I	HV	Opto-coupler cathode pin on the secondary side provides feedback signal to the primary side PWM controller.
15	VIN	Supply	HV	Supply input voltage. Connect this pin to GND via an 1uF ceramic capacitor
16	GND	Ground	HV	Power ground
17	-	Ground	-	Exposed ground if available

*Exposed pad is connected to GND if available



Hong Kong Office

Tel: (852) 36195375

Email: httadmin@hightt.com

URL: <https://www.hightt.com>

Address:

Unit 713, 7/F, 12W, 12 Science Park West Avenue,
Hong Kong Science Park, Shatin, Hong Kong