

HT6122S – High Efficiency, Dual Buck DC-DC Controller with Internal Protocol, Selectable Switching Frequency up to 700kHz

APPLICATION

- USB Type-C/Type-A fast charging applications
- LCD monitor/TV
- Desktop PC
- Automotive ADAS Power
- Low EMI Application (Patented dithering technique)

GENERAL DESCRIPTION

HT6122S is an easy to use, high efficiency, dual-channel, synchronous step-down switching controller designed for high-power dual ports fast charging applications. It has one channel built in QC Protocol for easy configuration to one Type-A and one Type-C fast charging output. With one channel of Type A fast charging, another channel is flexible to be used as a general-purpose DC-DC applications, fitting different needs of users' requirements.

HT6122S has a wide input voltage range from 4.7V to 36V, supports output voltages from 3.6V to 20V with typical current of 3.6A, the switching frequency is selectable to cover wide range of applications.

HT6122S has soft start function, which can prevent the inrush current at startup from affecting the stability of the input power.

HT6122S has a variety of protection, such as input overvoltage protection, undervoltage protection, output over current protection, overvoltage, undervoltage, short circuit protection, and etc.

FEATURES

Dual-Channel Synchronous Buck Controller

- Wide input voltage range: 4.7V to 36V
- Output current up to 3.6A, or higher
- One channel built in QC Protocol, reducing BOM
- External feedback for another channel
- Dual Channel Fast Charging simultaneously
- Selectable switching frequency at 300kHz, 500kHz and 700kHz
- Support CC / CV mode
- Soft start

Multi-Protection

- Input under-voltage lockout (UVLO)
- Output over-voltage protection (OVP)
- Output short-circuit protection (SCP)
- Over-temperature protection (OTP)

DEVICE INFORMATION

Part Number	Package	Dimensions (mm)
HT6122S	WQFN32	5.0 x 5.0 x 0.75

See package outline and dimensions on page 11.

Typical Application Circuit

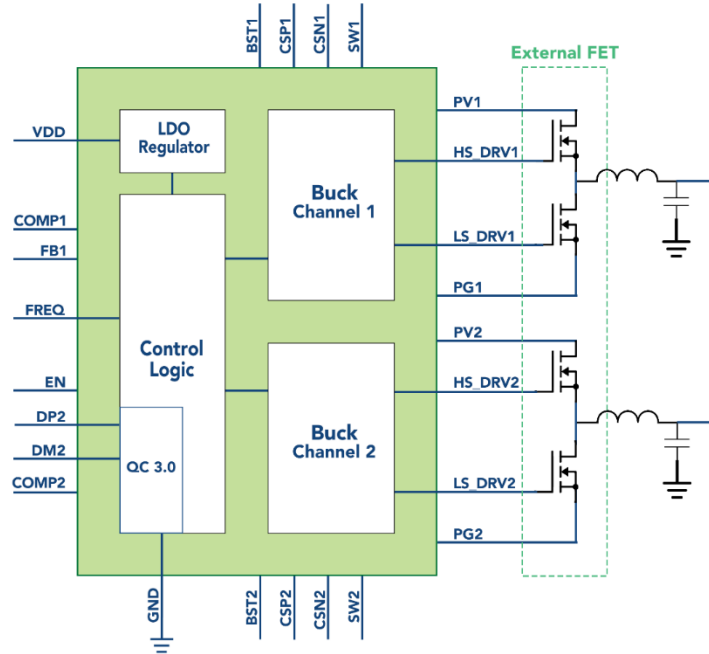

Fig. 1.1 – HT6122S Application Circuit

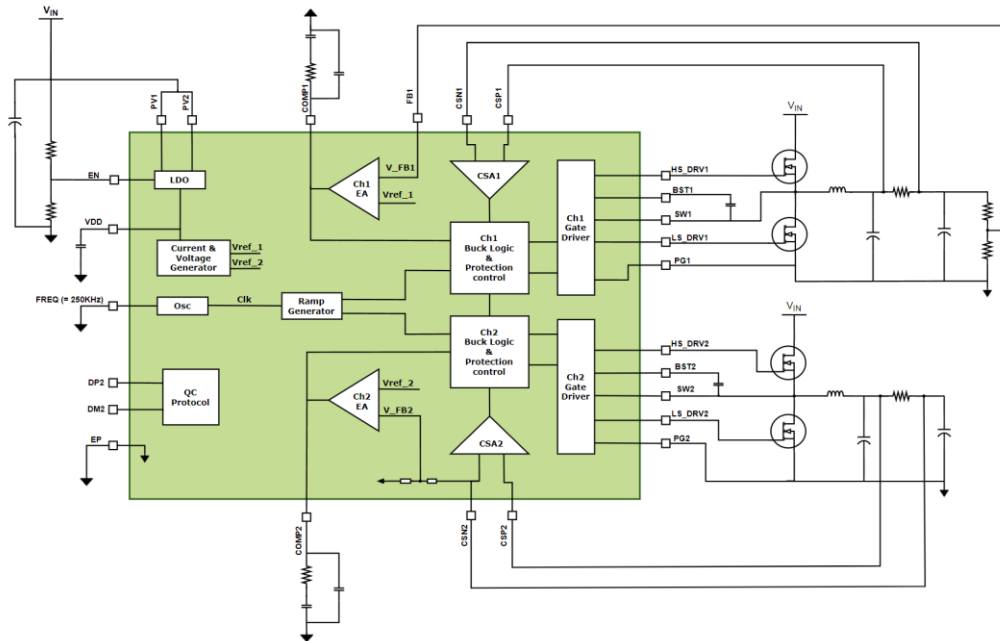

Fig. 1.2 – Detailed HT6122S Application Circuit

High Tech Technology Limited (HTT) reserves the right to make changes at any time, of any products or specifications herein, without further notice. HTT assumes no responsibility for the use of the information, nor does it assume any responsibility for any infringement of patents or other rights of third parties resulting from the use of the information. HTT does not grant any license under patent or patent rights, either implicitly or otherwise.

Pin Configuration

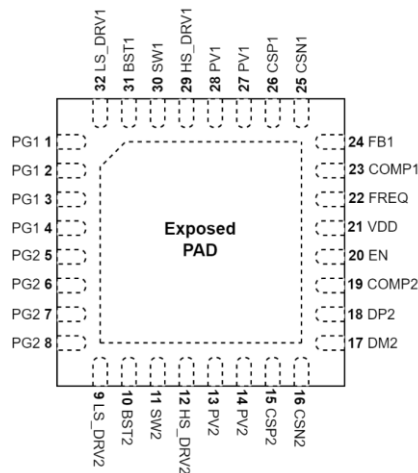

Fig. 2 - 32-pin QFN, 5x5 mm², 0.5mm pitch TOP VIEW

Pin Functions

Pin	Name	Description	Pin	Name	Description
1	PG1	Power Ground Channel 1	17	DM2	USB D- channel 2
2	PG1		18	DP2	USB D+ channel 2
3	PG1		19	COMP2	Compensation Pin 2
4	PG1		20	EN	Chip Enable, 1.35V enables the device
5	PG2	Power Ground Channel 2	21	VDD	VDD Regulator Connect a decoupling capacitor to GND. Recommended 2.2uF.
6	PG2		22	FREQ	Frequency Selection, See Application Information Section for detail
7	PG2		23	COMP1	Compensation Pin 1
8	PG2		24	FB1	Feedback Pin 1
9	LS_DRV2	Low Side Gate Drive Channel 2	25	CSN1	Current Sense Negative 1
10	BST2	Bootstrap Channel 2, Connect a capacitor (recommended 0.1uF) to SW2.	26	CSP1	Current Sense Positive 1
11	SW2	Inductor Connection Channel 2	27	PV1	Input Power Channel 1, Connect a capacitor (recommended 1uF) to GND.
12	HS_DRV2	High Side Gate Drive Channel 2	28	PV1	
13	PV2	Input Power Channel 2, Connect a capacitor (recommended 1uF) to GND.	29	HS_DRV1	High Side Gate Drive Channel 1
14	PV2		30	SW1	Inductor Connection Channel 1
15	CSP2	Current Sense Positive 2	31	BST1	Bootstrap Channel 1, Connect a capacitor (recommended 0.1uF) to SW1.
16	CSN2	Current Sense Negative 2	32	LS_DRV1	Low Side Gate Drive Channel 1
33	EPAD	Signal Ground and Thermal Dissipation Pad			

High Tech Technology Limited (HTT) reserves the right to make changes at any time, of any products or specifications herein, without further notice. HTT assumes no responsibility for the use of the information, nor does it assume any responsibility for any infringement of patents or other rights of third parties resulting from the use of the information. HTT does not grant any license under patent or patent rights, either implicitly or otherwise.

Absolute Maximum Ratings

Operation exceeding the Absolute Maximum Ratings may damage the device. If operating outside the Recommended Electrical Ratings but within the Absolute Maximum Ratings, device functionality and performance should not be assumed, and reliability may be affected.

PV1, PV2, SW1, SW2, EN	-0.3V to 40V
HS_DRV1, HS_DRV2, BST1, BST2	-0.3V to 36V
LS_DRV1, LS_DRV2	-0.3V to 6V
CSP1, CSN1, CSP2, CSN2	-0.3V to 22V
VDD, COMP1, COMP2, FB1, FREQ, DP2, DM2	-0.3V to 6V
Operating Temperature Range	-40°C to 85°C
Maximum Junction Temperature	-40°C to 125°C
Storage Temperature Range	-65°C to 125°C
Soldering Temperature	300°C

Electrical Characteristics

Limits apply over the operating temperature range, unless else specified. Max and Min limits are provided through design, test or statistical dependence. Typical values are the most likely parametric norm at room temperature, and are stated for reference only. Unless specified the following conditions apply: VIN = 12V, TA=25°C.

Parameters	Symbol	Test Conditions	Rating			Unit
			MIN	TYP	MAX	
Input Characteristics						
Operating Input Supply Voltage	V _{IN}		4.7		36	V
EN Threshold	V _{EN}			1.35		V
EN Hysteresis	V _{ENHYS}			110		mV
Quiescent Current	I _Q	Output at no load		1.5		mA
Shutdown Current	I _{stb}	VEN = 0V		20		μA
Output Characteristics*						
Channel 1 Output Voltage Range	V _{OUT1}	V _{IN} = 36V	3.6		20	V
Channel 1 Output Current Limit	I _{Limit_FB}	R _{SENSE} = 10mΩ		3.6		A
Channel 2 Output Voltage (QC3)	V _{OUT2_QC3}	QC5V: D+ = 0.6V, D- = 0V		5		V
		QC9V: D+ = 3.3V, D- = 0.6V		9		V
		QC12V: D+ = 0.6V, D- = 0.6V		12		V
	V _{STEP_QC3}	Cont.Mode: D+ = 0.6V, D- = 3.3V		200		mV
Channel 2 Output Current Limit (QC3)	I _{Limit_QC3}	R _{SENSE} = 10 mΩ, V _{OUT2} =5V		3.3		A
		R _{SENSE} = 10 mΩ, V _{OUT2} =9V		2.2		A
		R _{SENSE} = 10 mΩ, V _{OUT2} =12V		1.6		A
Channel 2 Fixed Cable Compensation Voltage	V _{CABLE}	V _{OUT2} = 5V, I _{OUT2} =3A		450		mV
Reference Voltage						
Output Voltage Reference	V _{FB}	Measured at FB1, FB2		1		V
Regulator Reference	V _{DD}	Measured at VDD		5.4		V

*Output load startup threshold = 1.5A

Electrical Characteristics

Limits apply over the operating temperature range, unless else specified. Max and Min limits are provided through design, test or statistical dependence. Typical values are the most likely parametric norm at room temperature, and are stated for reference only. Unless specified the following conditions apply: VIN = 12V, TA=25°C.

Parameters	Symbol	Test Conditions	Rating			Unit
			MIN	TYP	MAX	
Switching Characteristics						
Switching Frequency	f _{sw}	FREQ=Z		300		kHz
		FREQ=L		500		kHz
		FREQ=H		700		kHz
Minimum On-Time	t _{ON, Min}			80		ns
Dither Generator						
Dither Modulation Frequency	f _{DITH}			1560		Hz
Maximum Switching Frequency	f _{OSCMAX}			850		kHz
Minimum Switching Frequency	f _{OSCMIN}			700		kHz
Input Under-voltage Lockout						
Input Under-Voltage Lockout Threshold High	V _{UVLO}			4.7		V
Input Under-Voltage Lockout Hysteresis	V _{UVHYS}		0.53	0.64	0.71	V
Output Under-voltage Lockout						
Output Under-voltage Protection	V _{UVP}			V _{OUT} *60%		V
Output Over-voltage Protection						
Output Over-Voltage Protection	V _{OVp}			V _{OUT} *120%		V
Over-Temperature Protection						
Thermal Shutdown	T _{SD}	Increasing Temperature		140		°C
Thermal Shutdown Hysteresis	T _{SD,HYS}	Decreasing temperature		30		°C

Functional Block Diagram

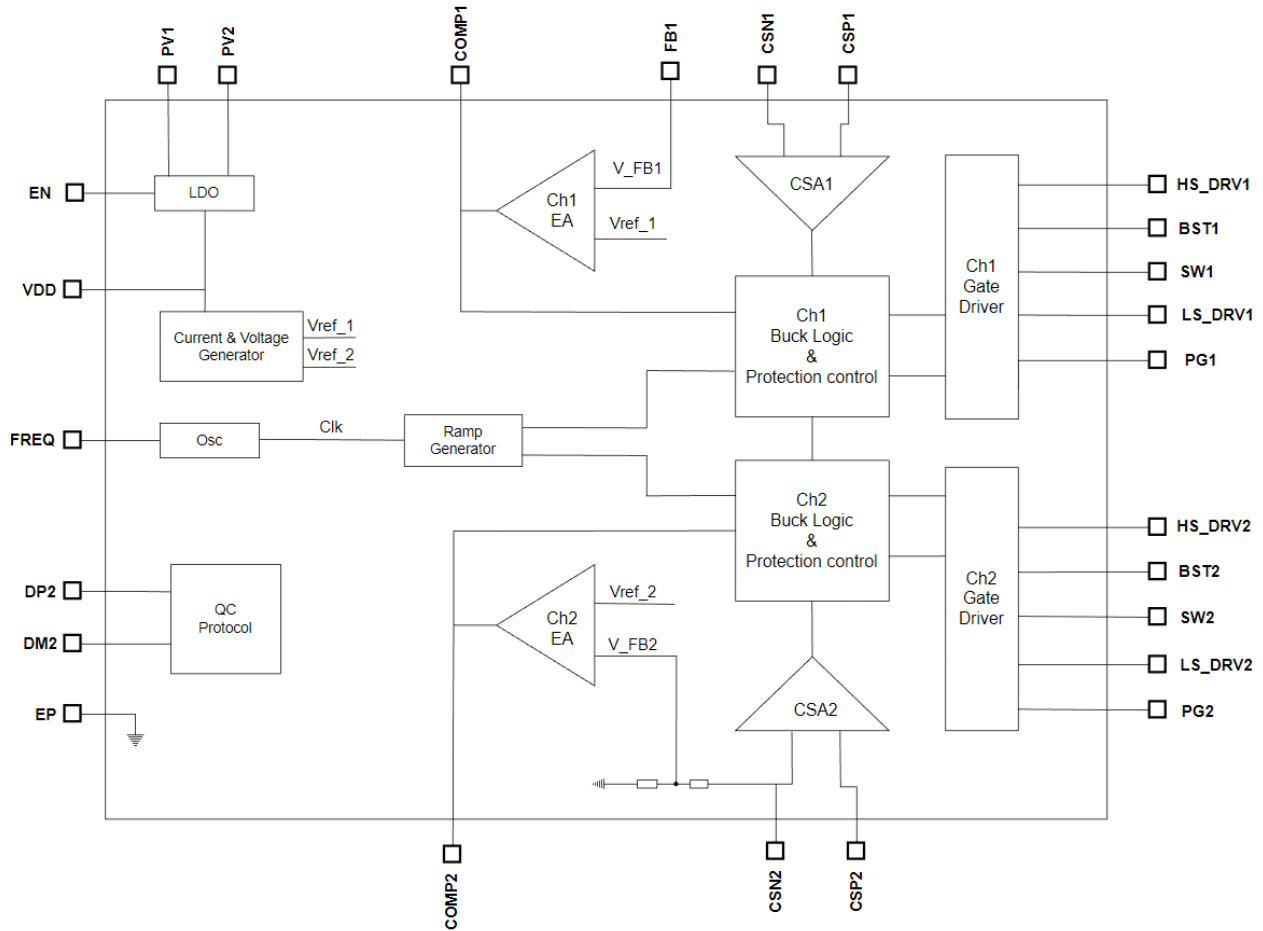

Fig. 3 – Functional Block Diagram

Application Information

Input Protection

If the input voltage is smaller than the Input UVLO, both buck channels stop the gate driver, reset and enter hiccup mode. It returns to Normal when the faults are cleared.

Output Protection

The Output Under-voltage Lockout threshold and the Output Over-voltage Protection are set at $V_{OUT} * 60\%$ and $V_{OUT} * 120\%$. Once Output UVLO or OVP is triggered, the specific channel stops the gate driver, reset and enters hiccup mode.

Soft Start

HT6000 series employs an internal soft start in the buck converter to prevent large inrush current and overshoots of V_{OUT} . The soft start time is 20ms in the design.

Feedback and Output Voltage

HT6122S provides an external FB for setting the output voltage. Usually, feedback resistor divider tap is connected and V_{FB} is regulated at 1V. The relationship between the V_{OUT} and the resistor divider tap is as follows:

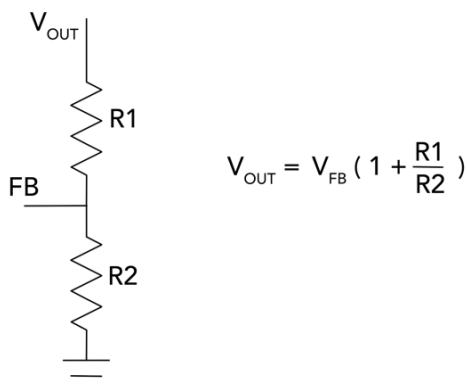

Fig. 4 – Feedback Resistor Network Design

Frequency Selection

The switching frequency can be selected by applying different condition to the pin FREQ.

FREQ state	f_{sw} (kHz)
Z	300
L	500
H (Tied to VDD)	700

The efficiency of the conversion depends on the switching FET. Usually, the efficiency is higher at lower frequency because of lower switching loss.

Efficiency and External FET R_{dson}

The accuracy of the output voltage and the conversion efficiency is highly affected by the R_{dson} of the external FET. The lower the R_{dson} the higher the efficiency and voltage accuracy.

Compensation Network

The output of the Error Amplifier is connected to COMP pin, allowing external control loop compensation. A type-II compensation network is recommended to ensure system stability.

Constant Voltage / Constant Current Mode

HT6122S has the capability to operate in either CV (constant voltage) mode or CC (constant current) mode, with a smooth transition from CV to CC (See Fig.5). When in CV mode, it regulates the output voltage. Once the output current limit threshold is reached, HT6122S switches to CC mode. In CC mode, the output voltage decreases while the output current remains clamped at the predefined values. The current limit can be determined using the following equation.

$$I_{out(max)} = \frac{36mV}{R_{sense}}$$

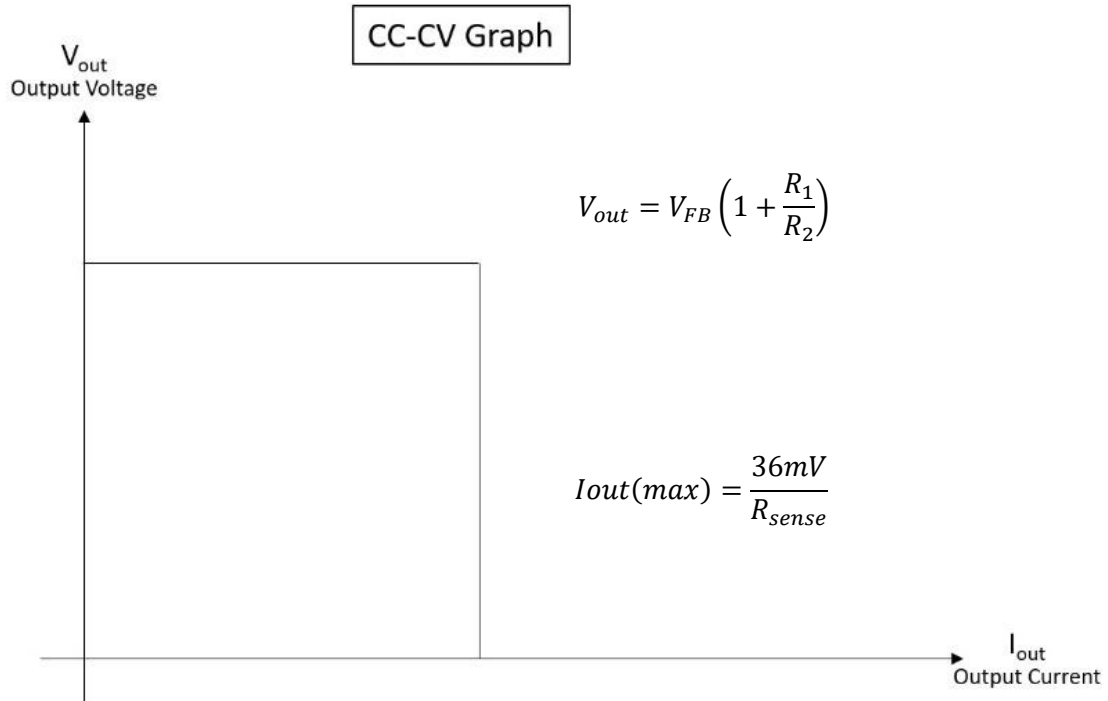

Fig. 5 - CC-CV Graph

HT6122S (Preliminary)

Typical Application Schematic

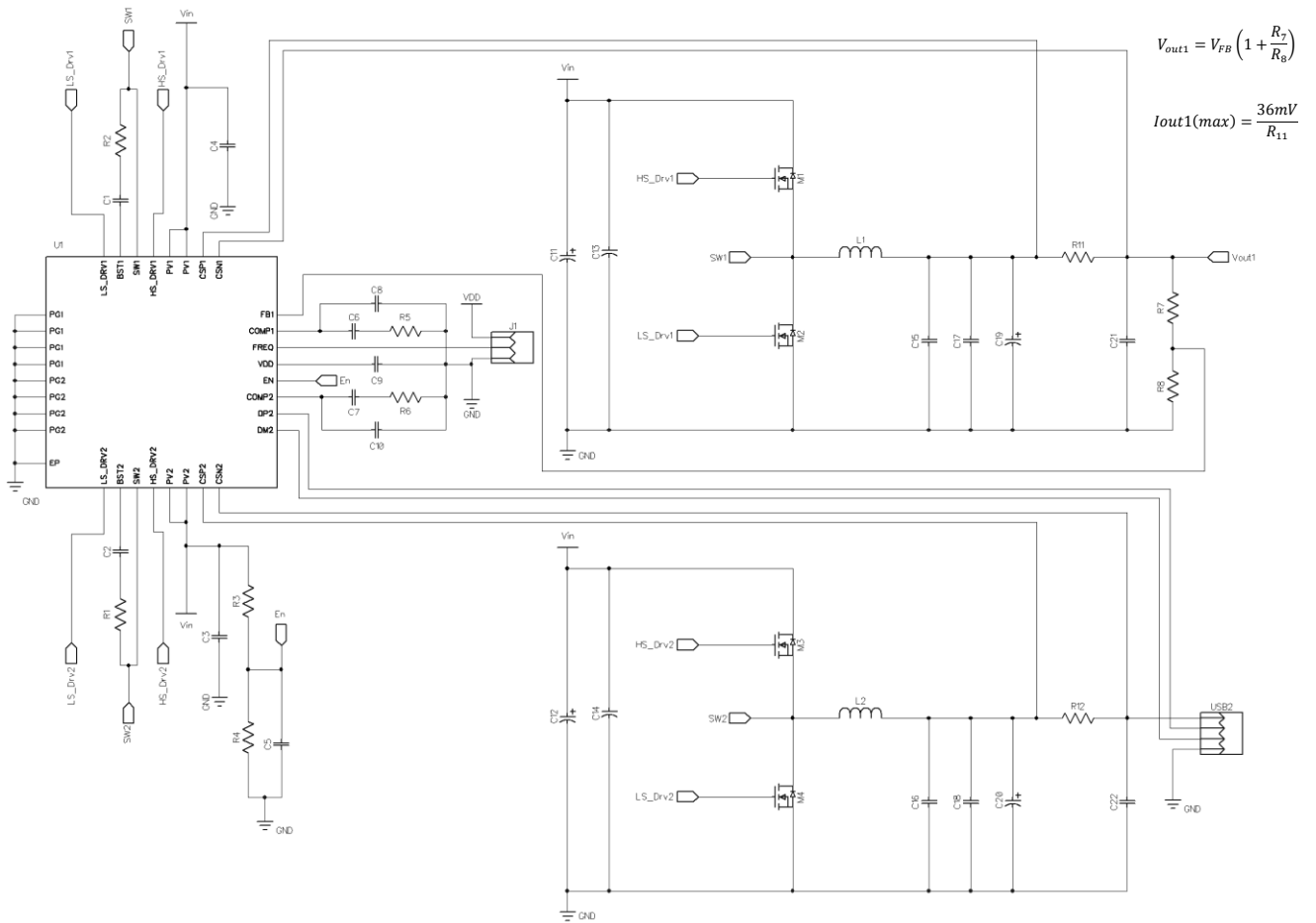
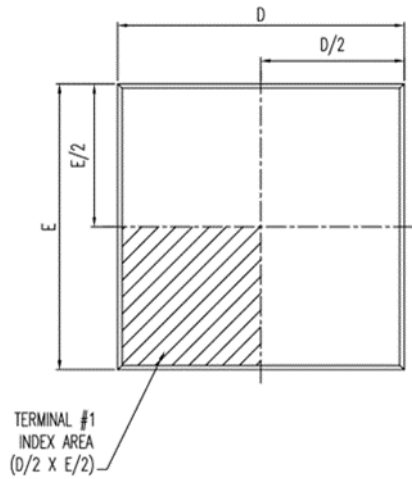

Fig. 6 - HT6122S application schematic diagram

Package Outline and Dimensions

32-pin QFN (5mm x 5mm, 0.5mm pitch)



Top View

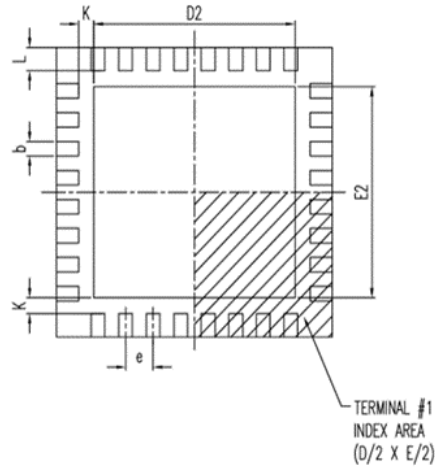

Bottom

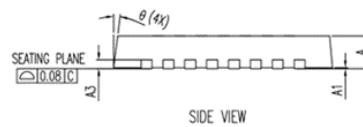

Side View

SYMBOL	DIMENSION IN MM		
	MIN.	NOM.	MAX.
A	0.70	0.75	0.80
A1	0	0.02	0.05
A3	0.20 REF.		
D	5.00 BASIC		
D2	3.50	3.65	3.80
E	5.00 BASIC		
E2	3.50	3.65	3.80
e	0.50 BASIC		
b	0.18	0.25	0.30
L	0.35	0.40	0.45
K	0.20		
θ	0°		14°
JEDEC	MO-220 (Variation WHHD-4)		

NOTES :

- ALL DIMENSIONS ARE IN MILLIMETERS.
- DIMENSION b APPLIES TO METALIZED TERMINAL AND IS MEASURED BETWEEN 0.15mm AND 0.30mm FROM THE TERMINAL TIP. IF THE TERMINAL HAS THE OPTIONAL RADIUS ON THE OTHER END OF THE TERMINAL, THE DIMENSION b SHOULD NOT BE MEASURED IN THAT RADIUS AREA.
- BILATERAL COPLANARITY ZONE APPLIES TO THE EXPOSED HEAT SINK SLUG AS WELL AS THE TERMINALS.

Dual Ports 

HT6000 Series

Fast Charging is just a Breeze



Hong Kong Office

Tel: (852) 36195375

Email: httadmin@hightt.com

URL: <https://hightt.com>

Address:

Unit 713, 7/F, 12W, 12 Science Park West Avenue,

Hong Kong Science Park, Shatin, Hong Kong