

# HT6422P - High Efficiency, Dual Buck DC-DC Converter with internal Protocol, operating frequency at 1MHz

## APPLICATION

- USB TypeC/TypeA fast charging applications
- LCD monitor/TV
- Desktop PC
- Automotive ADAS Power
- Low EMI Application (Patented dithering technique)

## GENERAL DESCRIPTION

HT6422P is an easy to use, high efficiency, dual-channel, synchronous step-down switching converter designed for high-power dual ports fast charging applications. It has one channel built in QC Protocol for easy configuration to one Type-A and one Type-C fast charging output. With one channel of Type A fast charging, another channel is flexible to be used as a general purpose DC-DC applications, fitting different needs of users' requirements.

Integrated with 4 power MOSFETs, HT6422P has a wide input range from 4.7 V to 36 V, it supports output voltages from 3.6V to 20V with typical current of 3A, operating frequency at 600kHz. Higher switching frequency may reduce the size and cost of external components such as inductors.

HT6422P has soft start function, which can prevent the inrush current at startup from affecting the stability of the input power.

HT6422P has a variety of protection, such as input overvoltage protection, undervoltage protection, output over current protection, overvoltage, undervoltage, short circuit protection, and etc

## FEATURES

### Dual-Channel Synchronous Buck converter

- Low  $R_{DS(ON)}$  internal power MOSFET 100m $\Omega$ /100m $\Omega$
- Wide input voltage range: 4.7V to 36V
- Output current up to 3A
- One channel built in QC Protocol
- External feedback for another channel
- Dual Channel Fast Charging simultaneously
- Switching frequency at 1MHz
- Support CC / CV mode
- Soft start

### Multi-Protection

- Input under-voltage lockout (UVLO)
- Output over-voltage protection (OVP)
- Output short-circuit protection (SCP)
- Over-temperature protection (OTP)

## DEVICE INFORMATION

Part Number	Package	Shipping
HT6422P	5x5 QFN32	490 / tray

See package outline and dimensions on p.10

## Typical Application Circuit

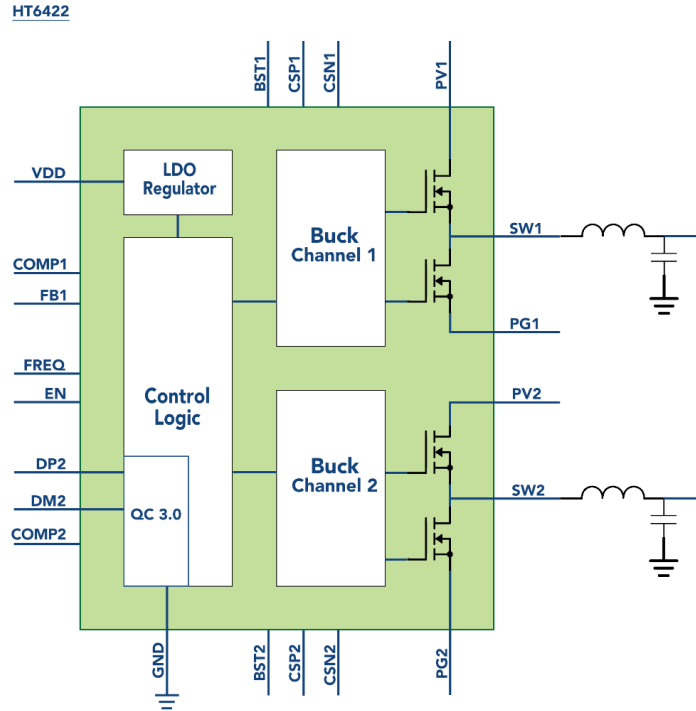

Fig. 1 HT6422P Block diagram

## Pin Configuration

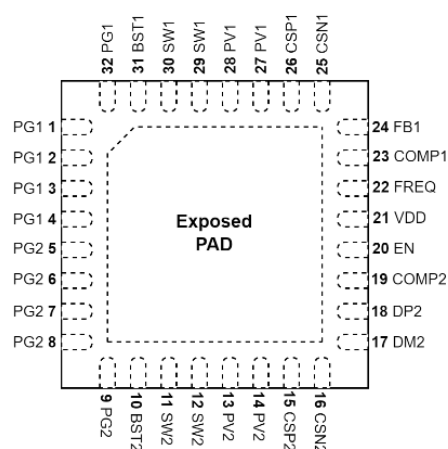

Fig. 3 32-pin QFN, 5x5 mm<sup>2</sup>, 0.5mm pitch TOP VIEW

## Pin Functions

Pin	Name	Description	Pin	Name	Description
1	PG1	Power Ground Channel 1	17	DM2	USB D- channel 2
2	PG1		18	DP2	USB D+ channel 2
3	PG1		19	COMP2	Compensation Pin 2
4	PG1		20	EN	Chip Enable, 1.35V enables the device
5	PG2	Power Ground Channel 2	21	VDD	VDD Regulator Connect a decoupling capacitor to GND. Recommended 2.2uF.
6	PG2		22	FREQ	Frequency Selection, See Application Information Section for detail
7	PG2		23	COMP1	Compensation Pin 1
8	PG2		24	FB1	Feedback Pin 1
9	PG2		25	CSN1	Current Sense Negative Channel 1
10	BST2	Bootstrap Channel 2, Connect a capacitor (recommended 0.1uF) in series with a 2ohm resistor to SW2.	26	CSP1	Current Sense Positive Channel 1
11	SW2	Inductor Connection Channel 2	27	PV1	Input Power Channel 1, Connect a capacitor (recommended 1uF) to GND.
12	SW2		28	PV1	
13	PV2	Input Power Channel 2, Connect a capacitor (recommended 1uF) to GND.	29	SW1	Inductor Connection Channel 1
14	PV2		30	SW1	
15	CSP2	Current Sense Positive Channel 2	31	BST1	Bootstrap Channel 1, Connect a capacitor (recommended 0.1uF) in series with a 2ohm resistor to SW1.
16	CSN2	Current Sense Negative Channel 2	32	PG1	Power Ground Channel 1
33	EPAD	Signal Ground & Thermal Dissipation Pad			

## Absolute Maximum Ratings

Operation exceeding the Absolute Maximum Ratings may damage the device. If operating outside the Recommended Electrical Ratings but within the Absolute Maximum Ratings, device functionality and performance should not be assumed, and reliability may be affected.

PV1, PV2, SW1, SW2, EN, BST1, BST2	-0.3V to 40V
CSP1, CSN1, CSP2, CSN2	-0.3V to 22V
VDD, COMP1, COMP2, FB1, DP2, DM2, FREQ	-0.3V to 6V
Operating Temperature Range	-40°C to 85°C
Maximum Junction Temperature	-40°C to 125°C
Storage Temperature Range	-65°C to 125°C
Soldering Temperature	300°C

## Electrical Characteristics

Limits apply over the operating temperature range, unless else specified. Max and Min limits are provided through design, test or statistical dependence. Typical values are the most likely parametric norm at room temperature, and are stated for reference only. Unless specified the following conditions apply:  $V_{IN} = 12V$ ,  $T_A = 25^\circ C$ .

Parameters	Symbol	Test Conditions	Rating			Unit
			MIN	TYP	MAX	
<b>Input Characteristics</b>						
Input Voltage	$V_{IN}$		4.7		36	V
Input under voltage lockout threshold High	$V_{UVLO}$			4.7		V
Input under voltage lockout Hysteresis	$V_{UVHYS}$		0.53	0.64	0.71	V
Quiescent current	$I_Q$	FREQ pin open		1.5		mA
Shutdown current	$I_{stb}$	$V_{en} = 0V$		20		uA
EN Threshold	$V_{EN}$			1.35		V
EN Hysteresis	$V_{ENHYS}$			110		mV
VDD regulator	$V_{REG}$			5.4		V
<b>Switching Characteristics</b>						
High Side MOSFET Turn On Resistance	$R_{DS\_HS(ON)}$			100		mΩ
Low Side MOSFET Turn On Resistance	$R_{DS\_LS(ON)}$			100		mΩ
Switching Frequency	$f_{sw}$			1000		kHz
Minimum Off-Time	$t_{OFF, Min}$			50		ns
<b>Output Characteristics</b>						
Output Voltage Range	$V_{OUT}$		3.3		20	V
Cycle by cycle Current Limit	$I_{OCP}$			3.6		A

High Tech Technology Limited (HTT) reserves the right to make changes at any time, of any products or specifications herein, without further notice. HTT assumes no responsibility for the use of the information, nor does it assume any responsibility for any infringement of patents or other rights of third parties resulting from the use of the information. HTT does not grant any license under patent or patent rights, either implicitly or otherwise.

Output Channel 1 control by FB						
Output voltage Reference	$V_{FB}$			1		V
Output Current limit	$I_{LIMIT\_FB}$	Rcs =10 mΩ		2.5		A
Output Channel 2 control by QC3						
Single Channel Output Voltage (QC3)	$V_{OUT\_QC3}$	QC5V: D+ = 0.6V, D- = 0V		5		V
		QC9V: D+ = 3.3V, D- = 0.6V		9		V
		QC12V: D+ = 0.6V, D- = 0.6V		12		V
		$V_{IN}=24V$ , QC20V: D+ = 3.3V, D- = 3.3V		20		V
	$V_{STEP\_QC3}$	Cont.Mode: D+ = 0.6V, D- = 3.3V		200		mV
Single Channel Output Current (QC3)	$I_{OUT\_QC3}$	Rcs = 10 mΩ, $V_{OUT}=5V$		3.3		A
		Rcs = 10 mΩ, $V_{OUT}=9V$		2.2		A
		Rcs = 10 mΩ, $V_{OUT}=12V$		1.6		A

## Electrical Characteristics

Limits apply over the operating temperature range, unless else specified. Max and Min limits are provided through design, test or statistical dependence. Typical values are the most likely parametric norm at room temperature, and are stated for reference only. Unless specified the following conditions apply:  $V_{IN} = 12V$ ,  $T_A=25^{\circ}C$ .

Parameters	Symbol	Test Conditions	Rating			Unit
			MIN	TYP	MAX	
<b>Protection</b>						
<b>Output Under-voltage Lockout</b>						
Output Under-voltage Protection	$V_{UVP}$			$V_{FB}^*$ 60%		V
<b>Output Over-voltage Protection</b>						
Output Over-Voltage Protection	$V_{OVP}$			$V_{FB}^*$ 120%		V
<b>Over-Temperature Protection</b>						
Thermal Shutdown	$T_{SD}$	Increasing Temperature		140		$^{\circ}C$
Thermal Shutdown Hysteresis	$T_{SD\_HYS}$	Decreasing temperature		30		$^{\circ}C$



## Application Information

### Input Protection

If the input voltage is higher than IVP or smaller than Input UVLO, both buck channels stop the gate driver, reset and enter hiccup mode. It returns to Normal when the faults are cleared.

### Output Protection

The Output Under-voltage Lockout threshold and the Output Over-voltage Protection are set at  $V_{OUT} * 60\%$  and  $V_{OUT} * 120\%$ . Once Output UVLO or OVP is triggered, the specific channel stops the gate driver, reset and enter hiccup mode.

### Soft Start

HT6000 series employs an internal soft start in the buck converter to prevent large inrush current and overshoots of  $V_{OUT}$ . The soft start time is 20ms in the design.

### Feedback and Output Voltage

HT6422P provides an external FB for setting the output voltage. Usually, feedback resistor divider tap is connected and  $V_{FB}$  is regulated at 1V. The relationship between the  $V_{OUT}$  and the resistor divider tap is as follows:

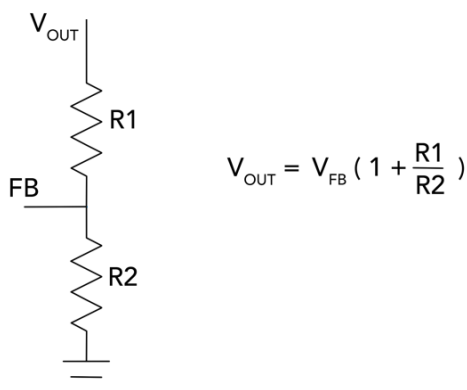

### Frequency Selection

The FREQ can be left floating to set the switching frequency to be 350kHz. The switching frequency can also be adjusted by an appropriate resistor connected from FREQ pin to GND. The relationship between the resistor and switching frequency is shown in Fig. 6. The efficiency of the conversion depends on the switching FET. The efficiency is usually slightly higher at lower frequency because of the lower switching loss.

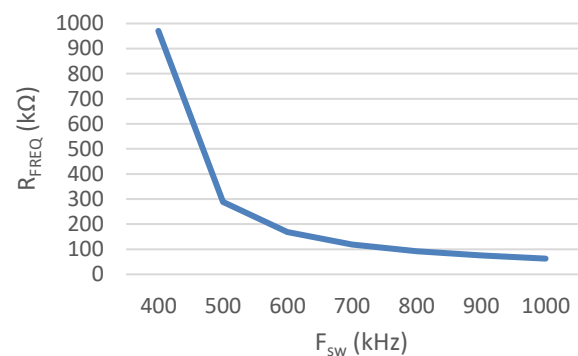

Fig. 6 – Switching frequency and resistor relationship

### Compensation Network

The output of the Error Amplifier is connected to COMP pin, allowing external control loop compensation. A type-II compensation network is recommended to ensure system stability.

### Constant Voltage / Constant Current Mode

HT6422P has the capability to operate in either CV (constant voltage) mode or CC (constant current) mode, with a smooth transition from CV to CC (See Fig.5). When in CV mode, it regulates the output voltage. Once the output current limit threshold is reached, HT6422P switches to CC mode. In CC mode, the output voltage decreases while the output current remains clamped at the predefined values. The current limit can be determined using the following equation.

$$I_{out(max)} = \frac{36mV}{R_{sense}}$$

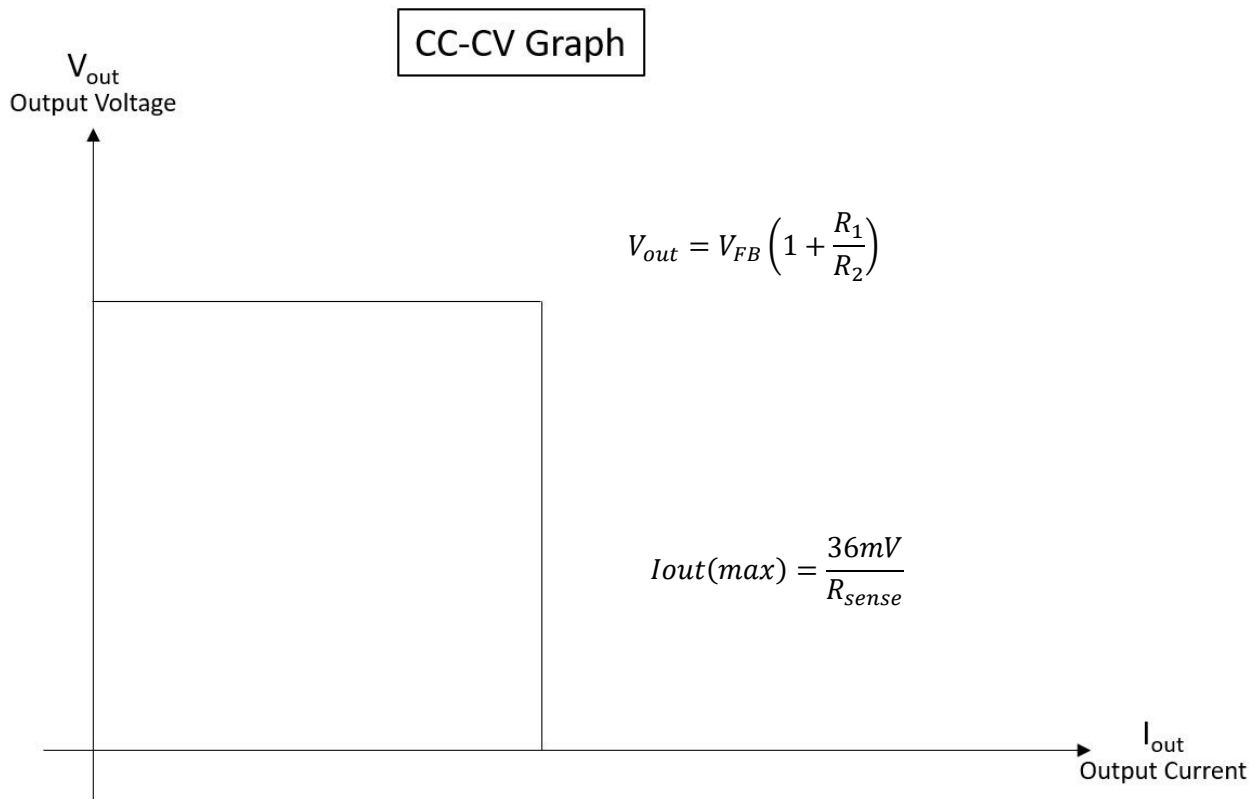

Fig. 2 CC-CV graph

**Typical Application Circuit**

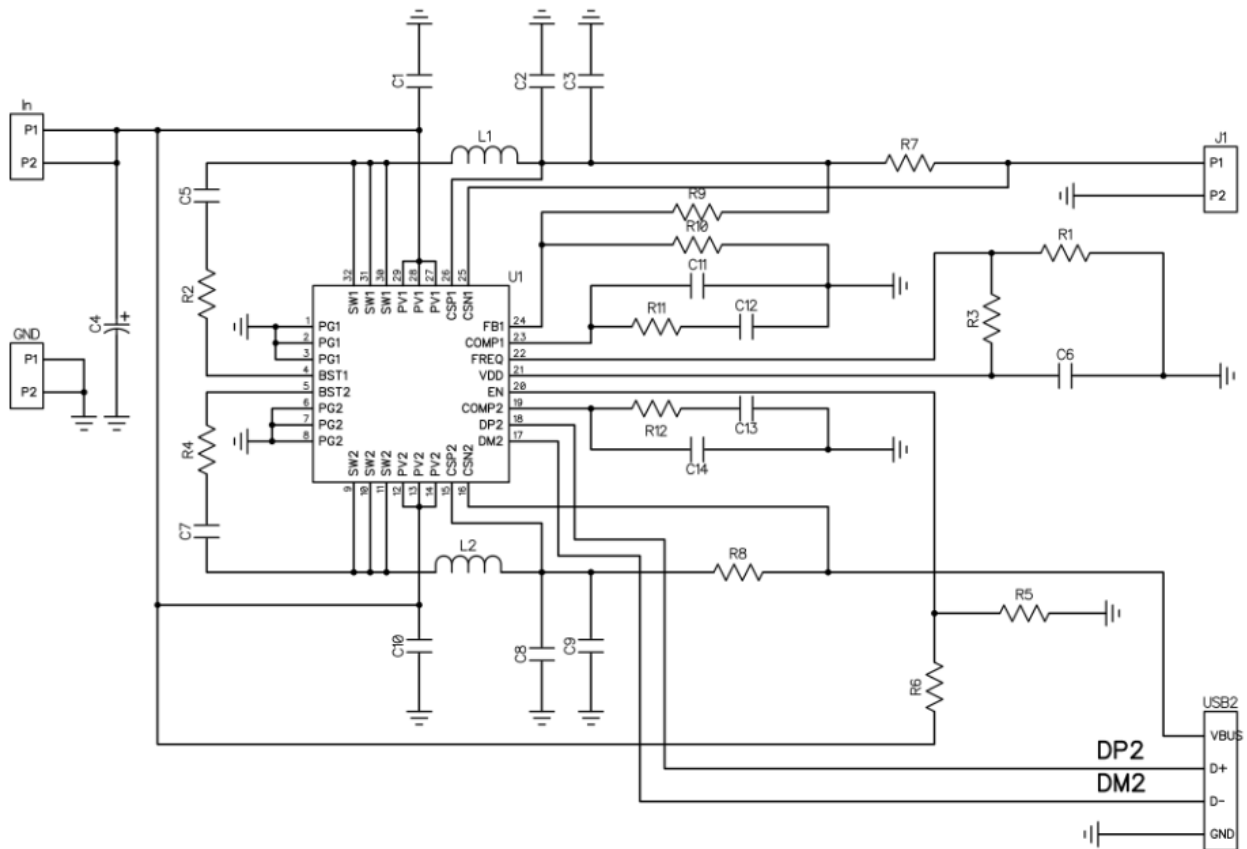
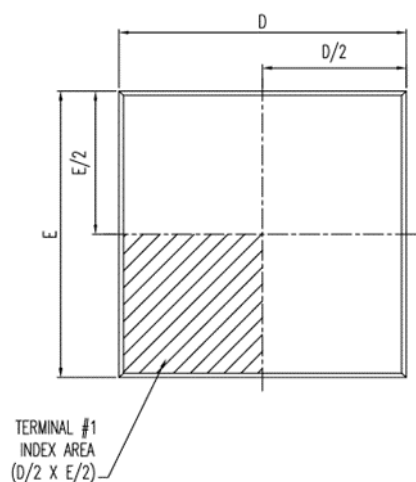
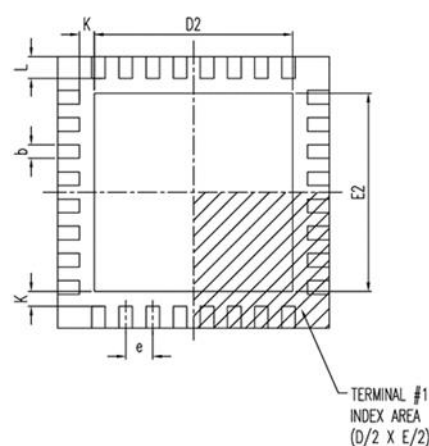

Fig. 4 HT6422P application schematic diagram

## Package Outline and Dimensions



Top View



Bottom

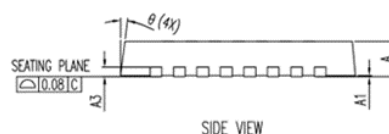

Side View

SYMBOL	DIMENSION IN MM		
	MIN.	NOM.	MAX.
A	0.70	0.75	0.80
A1	0	0.02	0.05
A3	0.20 REF.		
D	5.00 BASIC		
D2	3.50	3.65	3.80
E	5.00 BASIC		
E2	3.50	3.65	3.80
e	0.50 BASIC		
b	0.18	0.25	0.30
L	0.35	0.40	0.45
K	0.20		
θ	0°		14°
JEDEC	MO-220 (Variation WHHD-4)		

NOTES :

1. ALL DIMENSIONS ARE IN MILLIMETERS.
2. DIMENSION b APPLIES TO METALLIZED TERMINAL AND IS MEASURED BETWEEN 0.15mm AND 0.30mm FROM THE TERMINAL TIP. IF THE TERMINAL HAS THE OPTIONAL RADIUS ON THE OTHER END OF THE TERMINAL, THE DIMENSION b SHOULD NOT BE MEASURED IN THAT RADIUS AREA.
3. BILATERAL COPLANARITY ZONE APPLIES TO THE EXPOSED HEAT SINK SLUG AS WELL AS THE TERMINALS.

Fig. 5 32-pin QFN, 5mm x 5mm, 0.5mm pitch

Dual Ports 

**HT6000 Series**

Fast Charging is just a Breeze



Hong Kong Office

Tel: (852) 36195375

Email: [httadmin@hightt.com](mailto:httadmin@hightt.com)

URL: <https://hightt.com>

Address:

Unit 713, 7/F, 12W, 12 Science Park West Avenue,  
Hong Kong Science Park, Shatin, Hong Kong