



芯高科技
HIGH TECH
TECHNOLOGY LIMITED

Block Diagram of the power management system of Active Speaker

DISCLAIMER

這個文件內所有信息、產品圖片和顯示內容僅供參考。實際產品功能、成本和規格等（包括但不限於外觀、顏色和尺寸）以及實際顯示內容（包括但不限於背景、UI和圖標）可能會因時間及實際情況有所差異。這個文件內所有數據及比較是在特定情況下對比市面部份同類產品，均為內部實驗室通過特定條件下進行的測試獲得的理論值，如實際充電時間及快充模式兼容性等是可能因客觀環境而變化，所有結果會因此出現差異。由於個別產品、軟件版本、應用條件和環境因素的差異，實際數據可能會有不同。所有數據因實際使用而有所不同。受條款及細則約束，請參閱上述產品詳細和規格。有關更多信息、文件內容、產品信息、價格等如有更改，恕不另行通知。

All data, images and content in this document are for reference only. Actual function, cost and specification etc. (included but not limited to appearance, color and size) as well as content shown (included but not limited to background, UI and icons) may be subjected to changes according to time and actual situation. All data included in this document are compared with market products under specific circumstances. Theoretical values were attained by test under specific conditions at internal laboratory. For example, actual charging time and compatibility of Fast Charging Protocol are subjected to changes under different conditions, thus may leading to differ in results. Different software updates, application conditions and environment factor in individual product may lead to differ in experimental results. All data may differ from actual application and subjected to terms and conditions, please refer to details and specifications herein. We reserve the right to make changes at any time, of any products or specifications herein, without further notice.

#This slide shows the entire power system for an active speaker module with a block diagram.

*Audio Signal Processing Circuit could include different audio input. Supply voltage depends on usage.

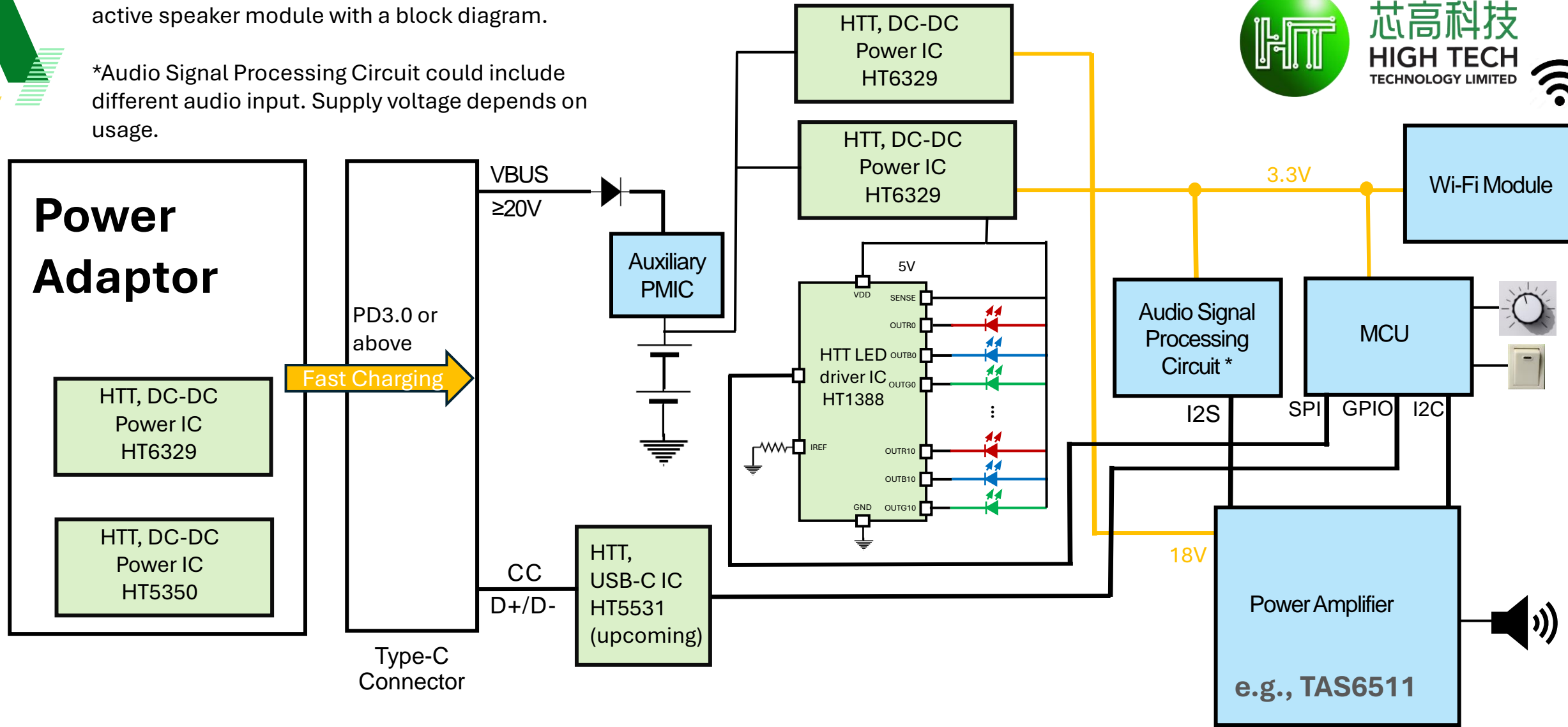

DISCLAIMER

這個文件內所有信息、產品圖片和顯示內容僅供參考。實際產品功能、成本和規格等（包括但不限於外觀、顏色和尺寸）以及實際顯示內容（包括但不限於背景、UI和圖標）可能會因時間及實際情況有所差異。這個文件內所有數據及比較是在特定情況下對比市面部份同類產品，均為內部實驗室通過特定條件下進行的測試獲得的理論值，如實際充電時間及快充模式兼容性等是可能因客觀環境而變化，所有結果會因此出現差異。由於個別產品、軟件版本、應用條件和環境因素的差異，實際數據可能會有不同。所有數據因實際使用而有所不同。受條款及細則約束，請參閱上述產品詳細規格。有關更多信息、文件內容、產品信息、價格等如有更改，恕不另行通知。
All data, images and content in this document are for reference only. Actual function, cost and specification etc. (included but not limited to appearance, color and size) as well as content shown (included but not limited to background, UI and icons) may be subjected to changes according to time and actual situation. All data included in this document are compared with market products under specific circumstances. Theoretical values were attained by test under specific conditions at internal laboratory. For example, actual charging time and compatibility of Fast Charging Protocol are subjected to changes under different conditions, thus may leading to differ in results. Different software updates, application conditions and environment factor in individual product may lead to differ in experimental results. All data may differ from actual application and subjected to terms and conditions, please refer to details and specifications herein. We reserve the right to make changes at any time, of any products or specifications herein, without further notice.

The above active speaker system's summary outlines

1. Proposed HTT IC (GREEN)
 - a) HT6329 (DC-DC Buck)
 - b) HT5350 (USB-C Source)
 - c) HT5531 (USB-C Sink)
 - d) HT1388 (RGB LED)
2. Outsourced IC (Blue)
 - a) Power Amplifier
 - b) WiFi module
 - c) Audio Signal Processing Circuit
 - d) MCU
 - e) Auxiliary PMIC
3. Allow charging from Type-C

For the datasheets of the mentioned HTT ICs, please refer to the PDFs inside the zipped file.

Their links are also provided here for your convenience:

HT6329: https://www.hightt.com/s/HT6329E_v1p5_Datasheet.pdf

HT5350: https://www.hightt.com/s/HT5350_datasheet.pdf

HT5531: See attachment.

HT1388: https://www.hightt.com/s/A01_HT1388_rev4e.pdf

DISCLAIMER

這個文件內所有信息、產品圖片和顯示內容僅供參考。實際產品功能、成本和規格等（包括但不限於外觀、顏色和尺寸）以及實際顯示內容（包括但不限於背景、UI和圖標）可能會因時間及實際情況有所差異。這個文件內所有數據及比較是在特定情況下對比市面部份同類產品，均為內部實驗室通過特定條件下進行的測試獲得的理論值，如實際充電時間及快充模式兼容性等是可能因客觀環境而變化，所有結果會因此出現差異。由於個別產品、軟件版本、應用條件和環境因素的差異，實際數據可能會有不同。所有數據因實際使用而有所不同，受條款及細則約束，請參閱上述產品詳細規格。有關更多信息、文件內容、產品信息、價格等如有更改，恕不另行通知。
All data, images and content in this document are for reference only. Actual function, cost and specification etc. (included but not limited to appearance, color and size) as well as content shown (included but not limited to background, UI and icons) may be subjected to changes according to time and actual situation. All data included in this document are compared with market products under specific circumstances. Theoretical values were obtained by test under specific conditions at internal laboratory. For example, actual charging time and compatibility of Fast Charging Protocol are subjected to changes under different conditions, thus may leading to differ in results. Different software updates, application conditions and environment factor in individual product may lead to differ in experimental results. All data may differ from actual application and subjected to terms and conditions, please refer to details and specifications herein. We reserve the right to make changes at any time, of any products or specifications herein, without further notice.