

HTT Product Introduction



Welcome to the Analog Era.

Bridging between the digital & quantum eras — HTT's brain-inspired Analog In-Memory Computing & RISC-V technology.

DISCLAIMER

這個文件內所有信息、產品圖片和顯示內容僅供參考。實際產品功能、成本和規格等（包括但不限於外觀、顏色和尺寸）以及實際顯示內容（包括但不限於背景、UI和圖標）可能會因時間及實際情況有所差異。這個文件內所有數據及比較是在特定情況下對比市面部份同類產品，均為內部實驗室通過特定條件下進行的測試獲得的理論值，如實際充電時間及快充模式兼容性等是可能因客觀環境而變化，所有結果會因此出現差異。由於個別產品、軟件版本、應用條件和環境因素的差異，實際數據可能會有不同。所有數據因實際使用而有所不同。受條款及細則約束，請參閱上述產品詳細和規格。有關更多信息、文件內容、產品信息、價格等如有更改，恕不另行通知。
All data, images and content in this document are for reference only. Actual function, cost and specification etc. (included but not limited to appearance, color and size) as well as content shown (included but not limited to background, UI and icons) may be subjected to changes according to time and actual situation. All data included in this document are compared with market products under specific circumstances. Theoretical values were attained by test under specific conditions at internal laboratory. For example, actual charging time and compatibility of Fast Charging Protocol are subjected to changes under different conditions, thus may leading to differ in results. Different software updates, application conditions and environment factor in individual product may lead to differ in experimental results. All data may differ from actual application and subjected to terms and conditions, please refer to details and specifications herein. We reserve the right to make changes at any time, of any products or specifications herein, without further notice.

IC Design, Production, Module & End Product Prototyping

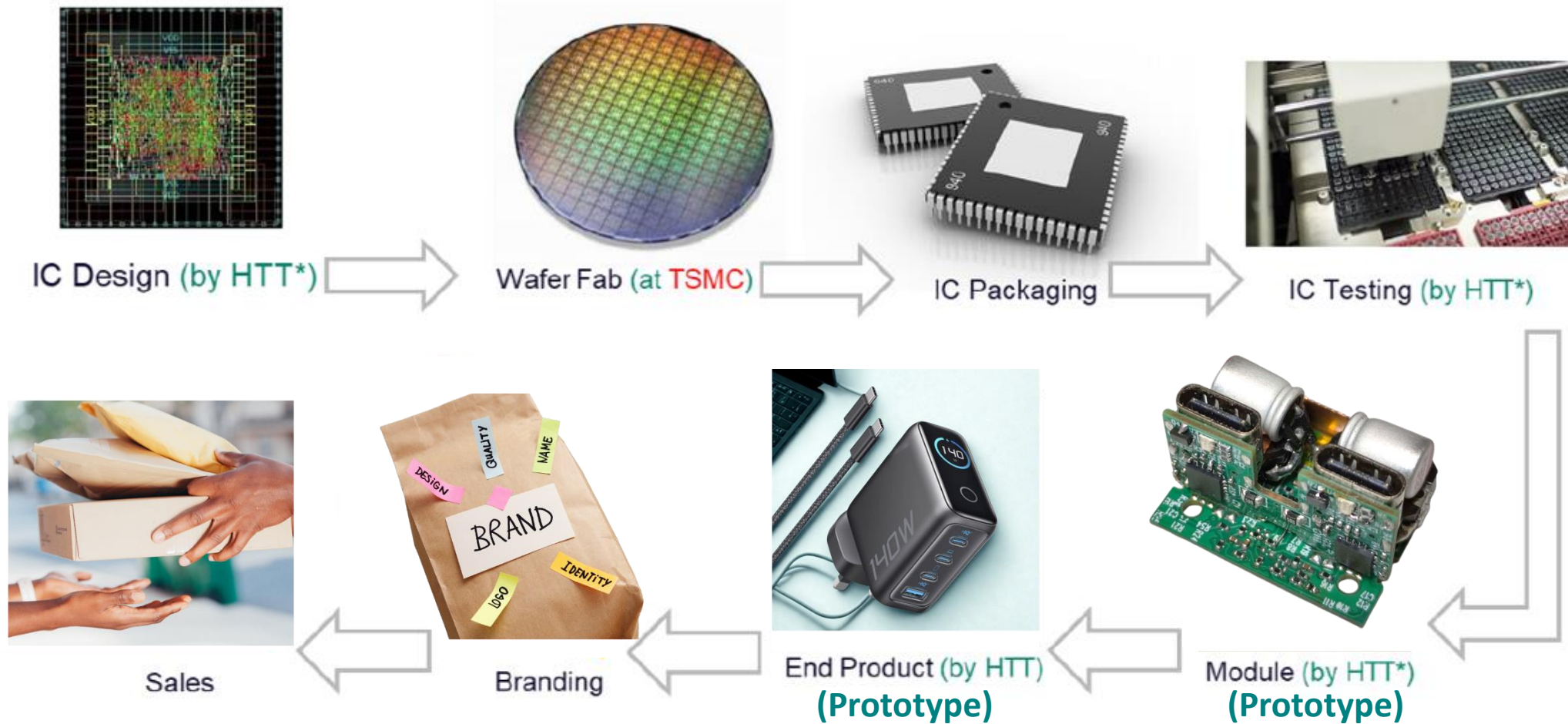

*HTT focus

Our Green Tech Series



RISC-V CPU

High-efficiency, low-power CPU core based on **open-source RISC-V architecture**, offering **scalable and customizable performance** for embedded and edge applications.



USB-C PD IC

Compact and efficient USB-C controller supporting **PD3.0, PD3.1 PD 3.2**, enabling **fast power delivery** and reliable connectivity for modern electronic devices.



Green Power IC

Advanced **power management solutions**, including **DC-DC converters** and **LED driver ICs**, designed for high efficiency and smart energy control across various applications.

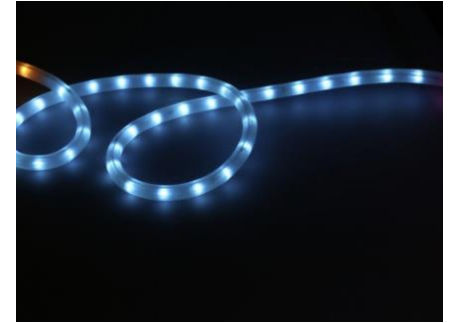

RGB-LED IC

Advanced LED driver solutions for **vibrant and efficient lighting**, supporting **multi-channel RGB control** for a wide range of applications.

RISC-V/CPU IC : High-Voltage Low-Power

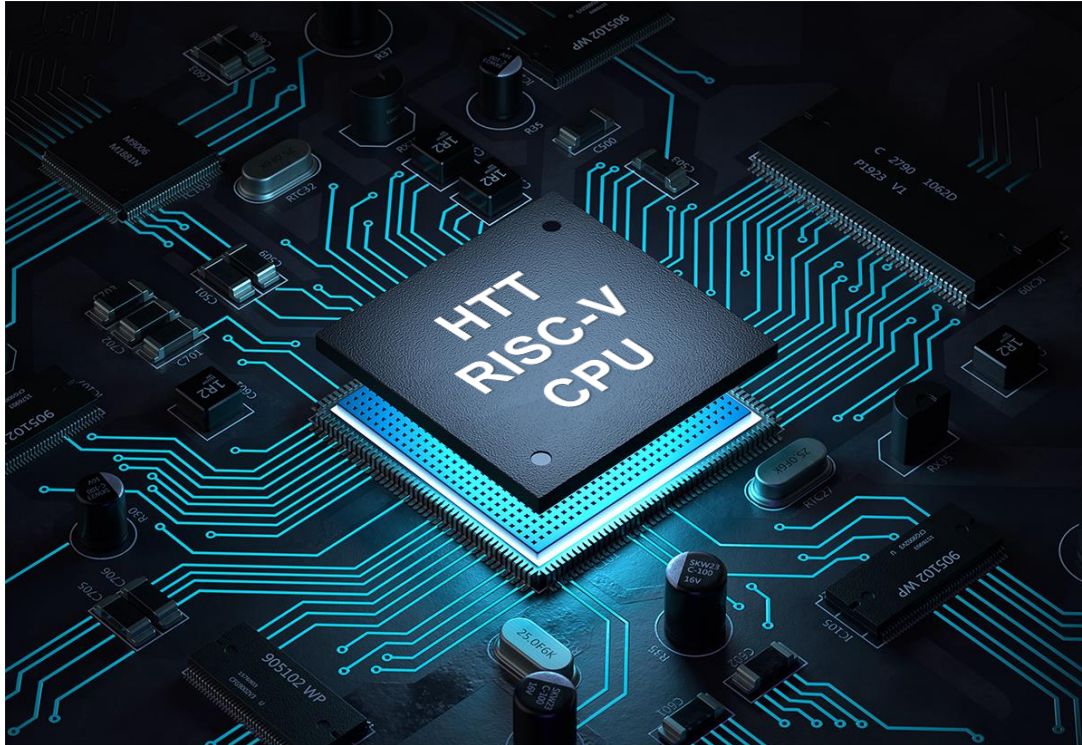

CPU IC Features

- Wide Operating Voltage Range
- Scalable Memory Options
- Comprehensive On-Chip Analog Peripherals
- Flexible I/O Ports
- Low-Power, High-Efficiency Cores
- ...

HT5580T: Energy-Efficient High-Voltage, Low-Power 32-bit, 28V-1.8V, RISC-V CPU



芯高科技
HIGH TECH
TECHNOLOGY LIMITED

FEATURES

- RISC-V Core
 - 32-bit, RISC-V microcontroller
 - Maximum Operating Frequency: 33MHz
 - RISC-V ISA (RV32EC)
 - Debug & Interface Port: By JTAG
 - Integrated Programmable Interrupt controller
 - Memory [1]
 - 64KB SRAM for program memory
 - 8KB SRAM for data memory
 - 64KB ROM (Optional)
 - 1Kb Flash/OTP (Optional)
 - Analog
 - 11-bit A/D Converter x 1
 - 8-bit D/A Converter x 2
 - Temperature Sensor
 - Internal CC-CV control for VIN regulation
 - Integrated VDD regulator
 - Timers
 - Programmable Watchdog Timer
 - 16-bit PWM Timer x 4
 - 32-bit Interval Timer x 3
 - 14 pins for general I/O Ports
 - Open drain
 - Programmable internal pull-up
 - Interrupt input
 - Operating Voltage
 - VIN: 5 to 28V
 - Max Input Voltage (VIN_max) = 28V
 - Package
 - 48 -pin WQFN (7mm x 7mm, 0.75 mm pitch)
- ## APPLICATIONS
- General purpose MCU core
 - USB-C PD controller
 - CC-CV controller
 - IoT and Smart Devices

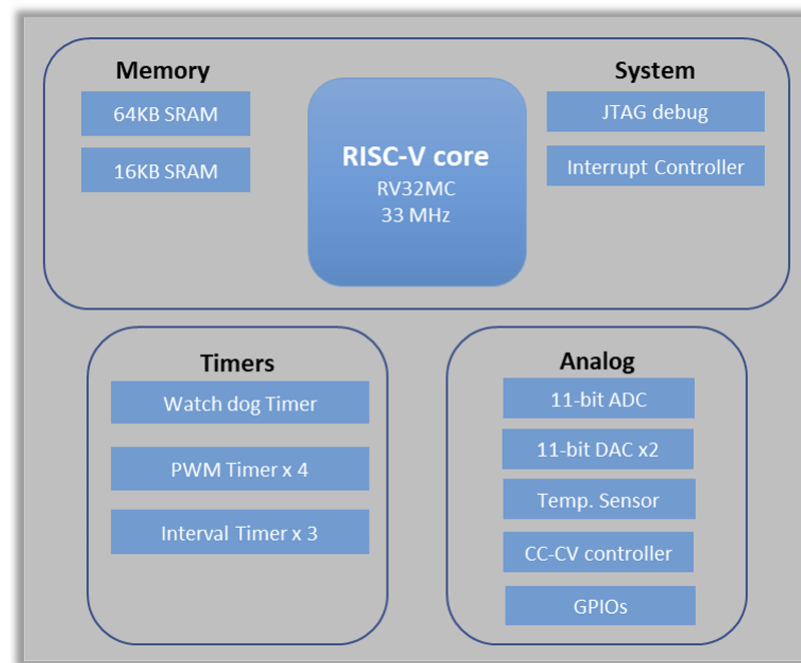

HT5380: Energy-Efficient, High-Voltage, Low-Power 8-bit, 20V-1.8V, 8051 1T CPU



芯高科技
HIGH TECH
TECHNOLOGY LIMITED

FEATURES

- 1T-8051 8-bit Core
 - Maximum Operating Frequency: 9.6MHz
 - Integrated Interrupt controller
- Memory [1]
 - 32KB SRAM program memory
 - 4KB SRAM data memory
 - 8Kb Flash/OTP (Optional)
 - 32KB ROM (Optional)
 - 2kB SRAM (optional)
- Connectivity
 - I2C Bus interface
 - Serial interface UART
 - 1-wire interface
- Analog
 - 11-bit A/D Converter x 1
 - 8-bit D/A Converter x 2
 - Temperature Sensor
 - Internal CC-CV control for VIN regulation
 - Integrated VDD regulator
- Timers
 - Watchdog Timer
 - Interval Timer x 3
- 8 pins for general I/O Ports
 - Open drain, connectable to 3.3V, 1.8V, or other voltages.
 - Programmable internal pull-up
 - Interrupt input
- Operating Voltage
 - VIN Range: 5V to 22V
 - Max input Voltage (VIN_max): 22V
- Package
 - 48 -pin WQFN (7mm x 7mm, 0.75 mm pitch)

APPLICATIONS

- General purpose MCU core
- USB-C PD controller
- CC-CV controller
- IoT and Smart Devices
- Consumer Electronics

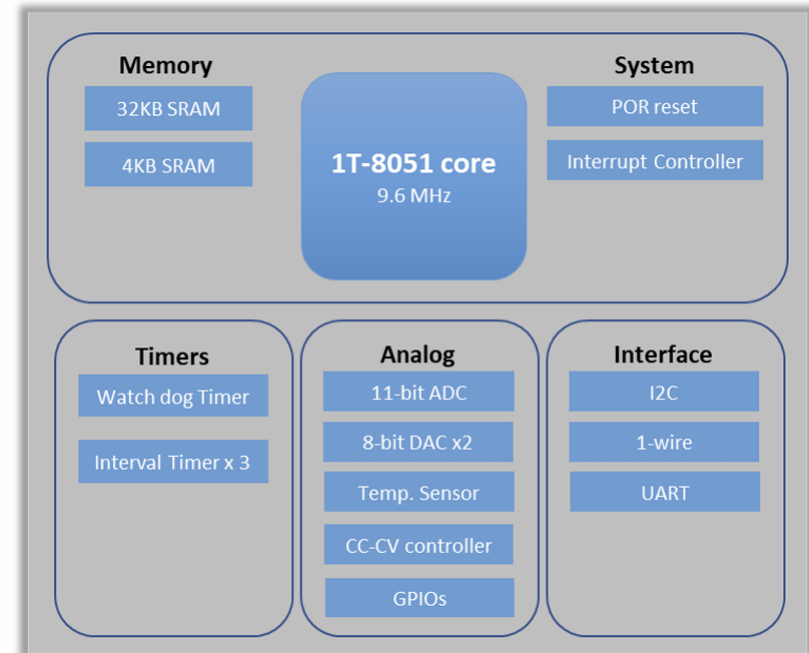

USB-C Protocol IC : HT5000 Series

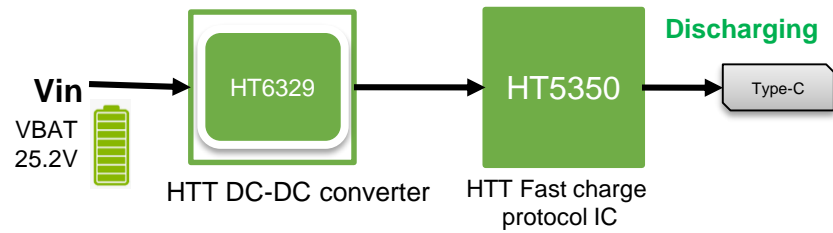

HT5350 USB-C Power Giver (Source)

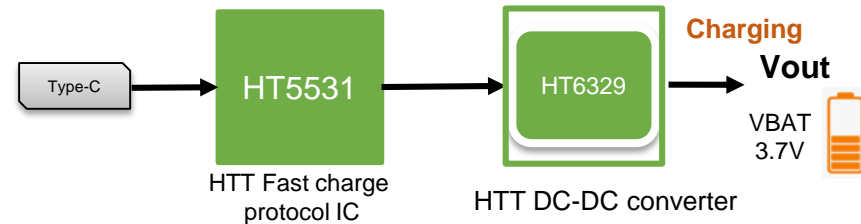

HT5531 USB-C Power Taker (Sink)

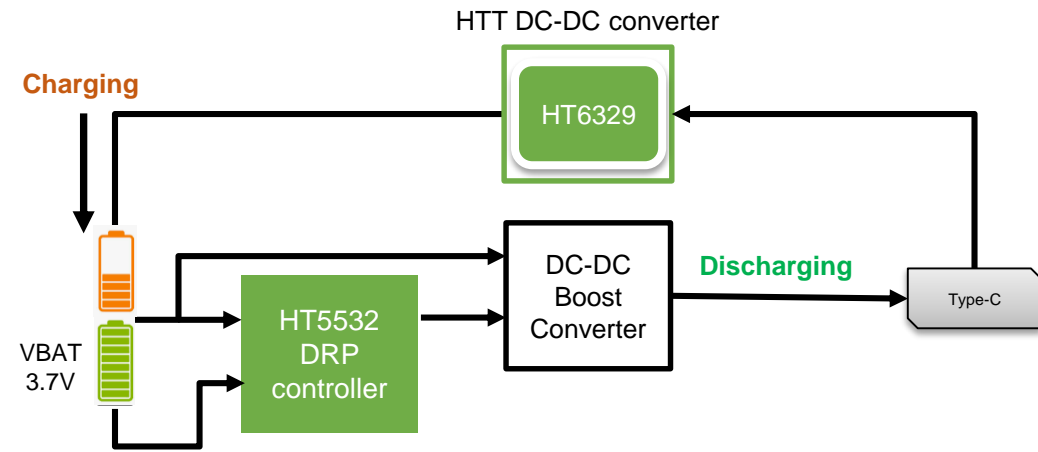

HT5532 USB-C PD3.1 Giver+Taker (DRP)

HTT Protocol IC

	USB-C PD Power Giver (Source)	USB-C PD Power Taker (Sink) (Coming Soon)	USB-C PD Power Giver+Taker (DRP)
HTT Protocol IC	HT5350 (PD3.0), 100W HT5530 (PD3.1), 140W HT5533 (PD3.2), 140W	HT5531(PD3.1), 140W HT5534 (PD3.2), 140W	HT5532 (PD3.1), 140W HT5535 (PD3.2), 140W
Application	AC-DC Adapter, Car Charger	Smartphones, Laptops, USB-C accessories	Power banks, laptops, smartphones
Supported Output Voltage		5V, 9V, 12V, 15V, 20V, PPS (PD 3.0) AVS, 28V(PD3.1/3.2 only)	
Protocol Support		QC2.0 / QC3.0, PD3.0/3.1/3.2, BC1.2 DCP	

HT5350: USB-C PD3.0 100W Source (Power Giver)

1. FEATURES

- USB PD3.0 and Type-C 1.3
- Support up to Five FPDOs
 - Typical 5V, 9V, 12V, 15V and 20V FPDOs
- Support up to three APDOs
 - Support 5V-Prog, 9V-Prog, 15V-Prog and 20V-Prog
 - 20mV LSB Voltage Regulation and 50mA LSB for Current Regulation
 - Constant power limit
- Support QC2.0/QC3.0, BC1.2 DCP protocols
 - Apple 5V, 2.4A mode
 - BC1.2 DCP mode
 - QC2.0 5V/9V/12V and 20V
 - QC3.0 3.6V~20V continuous model voltage mode with 200mV step adjustment
 - Support Fast Charging Protocol, FCP
 - Support Adaptive Fast Charging, AFC
- Constant Voltage (CV) and Constant Current Limit (CC) Regulation
 - Integrated secondary side compensation circuit, such as TL431
- Built-in VIN and VBUS pins fast discharge scheme
- Small Current Sensing Resistor (5mΩ) for High Efficiency application
- CC1/CC2 Pin Protection up to 28V
- Support cable drop compensation with 0, 50m, 100m/200mΩ selection
- Support Smart Power Derating function at two ports USB application (USB-C or USB-A)
- Integrated VCONN power and eMarker detection

2. APPLICATIONS

- AC-DC PD Compliant power adapters
- DC-DC Car chargers
- USB-PD converter

4. PART NUMBER INFORMATION

PART NO.	PACKAGE	Dimensions (mm)
HT5350	QFN16	4.0 x 4.0 x 0.75

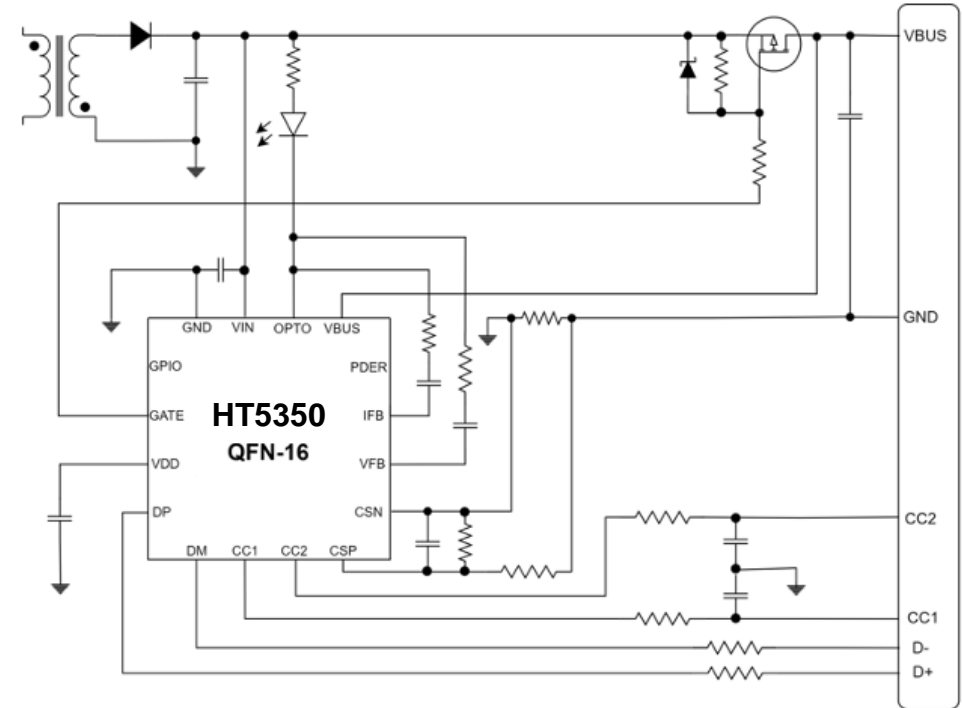

Typical Application Circuit of HT5350



HT5531: USB-C PD 3.1 High-Voltage Low-Power RISC-V 140W Sink (Power Taker) Controller

FEATURES

- 32-bit, RISC-V microcontroller
- USB-C PD 3.1 and Type-C 1.3
- Supports to sink PDO configurable profiles (up to 28V, 5A)
- Supports PPS with 20mV/step voltage and 50mA/step current
- Supports Legacy charging sink at DPDM protocols
 - Apple 5V, 2.4A mode
 - BC1.2 DCP detection
- Embeds protection schemes on VBUS, such as Under Voltage Protection (UVP), Over Voltage Protection (OVP), Over Current Protection (OCP)
- Supports Over Temperature protection (I_OTP) from NTC resistor
- CC1 and CC2 pins Over Voltage Protection (CC_OVP) and rating up to 28V
- Operating Voltage Range: 3.3V to 30V
- Supports Dead Battery Mode
- Supports Sleep Mode
- Low Power Consumption

APPLICATIONS

- USB-C cables (with E-marker)
- USB PD sink devices
- Lithium battery appliances
- Wireless charger

DEVICE INFORMATION

Part Number	Package	Dimensions (mm)
HT5531	QFN16	4.0 x 4.0 x 0.75

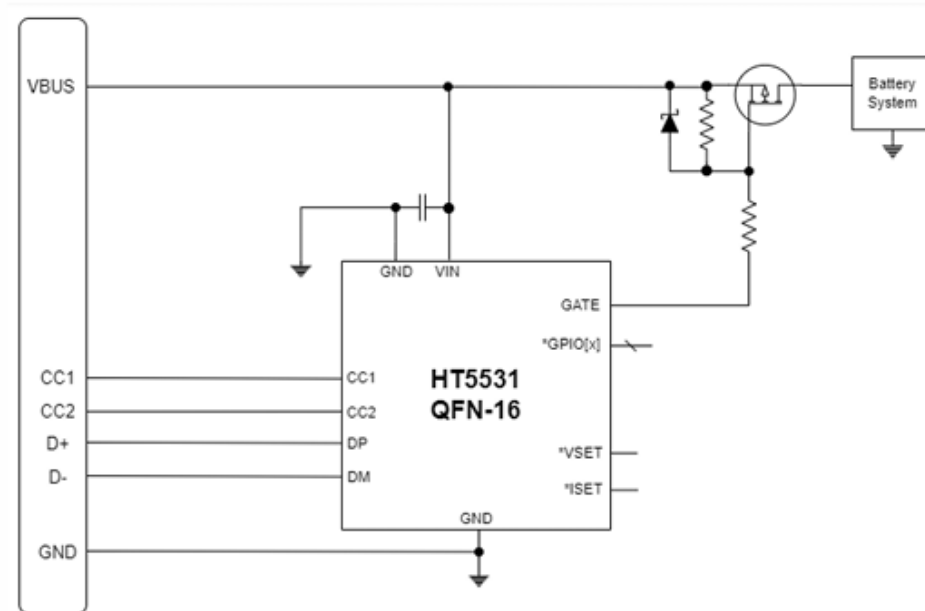

Typical Application Circuit of HT5531



HT5532: USB-C PD 3.1 High-Voltage Low-Power RISC-V 140W Dual-Role Port (Power Giver+Taker) Controller

FEATURES

- 32-bit RISC-V microcontroller, Integrated Type-C USB PD3.1 Source/Sink DRP with Try.SRC Protocol
- Maximum 140W power supply
- Type-C detect Sink / Source attached to activate discharge/charge circuit
- 28V EPR FPDO, EPR AVS and PPS Supported
 - FPDO: 5V 3A, 9V 3A, 12V 3A, 15V 3A, 20V 5A EPR FPDO: 28V 5A
 - EPR AVS: 15V - 28V 5A
 - PPS: 5V - 21V 5A
- Multiple DPDM Charging Protocols Implemented
 - Apple 5V, 2.4A mode
 - BC1.2 DCP mode
 - QC2.0 5V/9V/12V and 20V
 - QC3.0 3.6V~20V continuous model voltage mode with 200mV step adjustment
- Sleep Mode
- EN Wake-up function
- Built-in VIN and VBUS pins fast discharge scheme
- Type-C Connector Pins Protection up to 28V
- Support cable drop compensation with 0, 50m, 100m/200mΩ selection
- Built-in adaptive UVP, adaptive OVP, I_OTP, CC_OVP and Fault Detections
- Low Power Consumption

APPLICATIONS

- Power Bank
- Fast Charger Adaptor
- Consumer Electronics
- Laptop Computer
- 2 to 6 cells Lithium battery/lithium iron phosphate battery charging and discharging

DEVICE INFORMATION

Part Number	Package	Dimensions (mm)
HT5532	QFN24	4.0 x 4.0 x 0.75

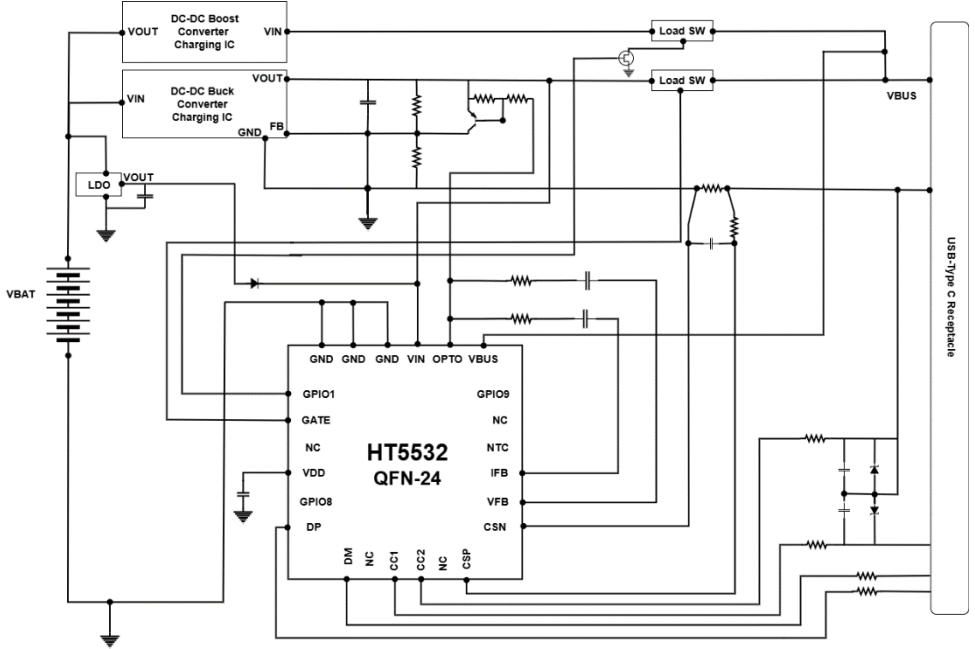

Typical Application Circuit of HT5532

HT5533: USB-C PD 3.2 High-Voltage Low-Power RISC-V 140W Source (Power Giver) Controller

FEATURES

- 32-bit, RISC-V microcontroller
- USB-C 1.3 (PD3.2)
- Maximum charging power 140W
- 28V EPR FPDO, EPR AVS and PPS Supported
 - FPDO: 5V 3A, 9V 3A, 12V 3A, 15V 3A, 20V 5A EPR FPDO: 28V 5A
 - SPR AVS: 9V - 20V 5A
 - EPR AVS: 15V - 28V 5A
 - PPS: 5V - 21V 5A
- Multiple DPDM Charging Protocols Implemented
 - Apple 5V, 2.4A mode
 - BC1.2 DCP mode
 - QC2.0 5V/9V/12V and 20V
 - QC3.0 3.6V~20V continuous model voltage mode with 200mV step adjustment
- Constant Voltage (CV) and Constant Current Limit (CC) Regulation
 - Integrated secondary side compensation circuit, such as TL431
- Built-in VIN and VBUS pins fast discharge scheme
- Small Current Sensing Resistor (5mΩ) for High Efficiency application
- CC1/CC2 Pin Protection up to 28V
- Support cable drop compensation with 0, 50m, 100m/200mΩ selection
- Support Smart Power Derating function at two ports USB application (USB-C or USB-A)
- Integrated VCONN Power for e-Marker Detection
- Sleep Mode Supported
- Low Power Consumption

APPLICATIONS

- Fast Charge Adaptors
- Car Chargers
- Travel Adaptors
- Note Book Computers

DEVICE INFORMATION

Part Number	Package	Dimensions (mm)
HT5533	QFN16	4.0 x 4.0 x 0.75

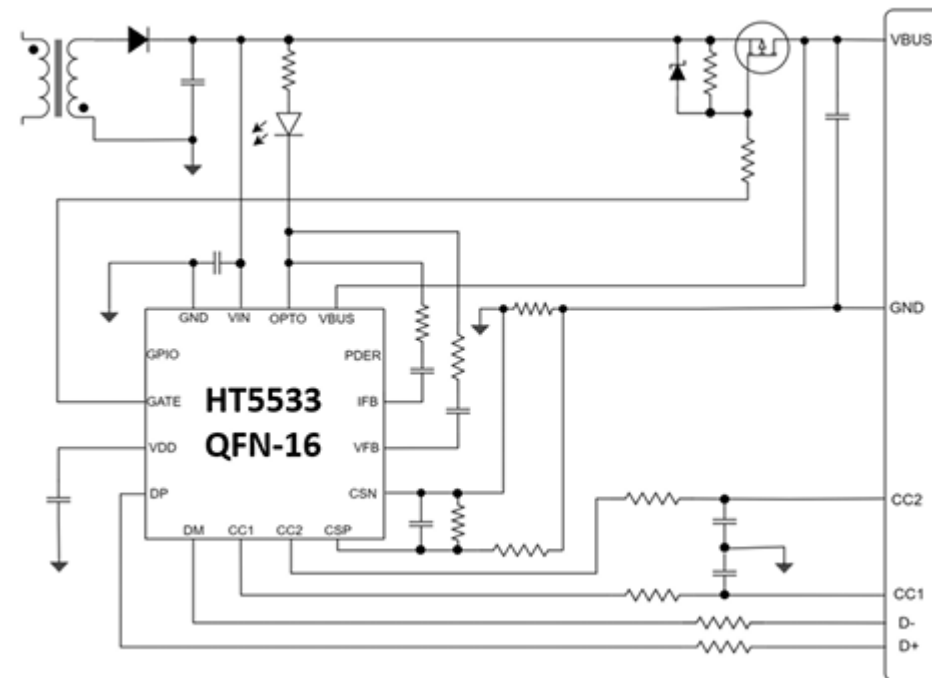

Typical Application Circuit of HT5533

HT5535: USB-C PD 3.2 High-Voltage Low-Power RISC-V 140W Dual-Role Port (Power Giver+Taker) Controller



FEATURES

- 32-bit RISC-V microcontroller, Integrated Type-C USB compliant with PD3.2 Rev.1.0
- Source/Sink DRP with Try.SRC Protocol
- Maximum 140W power supply
- Type-C detect Sink / Source attached to activate discharge/charge circuit
- 28V EPR FPDO, EPR AVS and PPS Supported
 - FPDO: 5V 3A, 9V 3A, 12V 3A, 15V 3A, 20V 5A EPR FPDO: 28V 5A
 - SPR AVS: 9V - 20V 5A
 - EPR AVS: 15V - 28V 5A
 - PPS: 5V - 21V 5A
- Multiple DPDM Charging Protocols Implemented
 - Apple 5V, 2.4A mode
 - BC1.2 DCP mode
 - QC2.0 5V/9V/12V and 20V
 - QC3.0 3.6V~20V continuous model voltage mode with 200mV step adjustment
- Sleep Mode
- EN Wake-up function
- Built-in VIN and VBUS pins fast discharge scheme
- Type-C Connector Pins Protection up to 28V
- Support cable drop compensation with 0, 50m, 100m/200mΩ selection
- Built-in adaptive UVP, adaptive OVP, I_OTP, CC_OVP and Fault Detections
- Low power consumption

APPLICATIONS

- Power Bank
- Fast Charger Adaptor
- Consumer Electronics
- Laptop Computer
- 2 to 6 cells Lithium battery/lithium iron phosphate battery charging and discharging

DEVICE INFORMATION

Part Number	Package	Dimensions (mm)
HT5535	QFN24	4.0 x 4.0 x 0.75

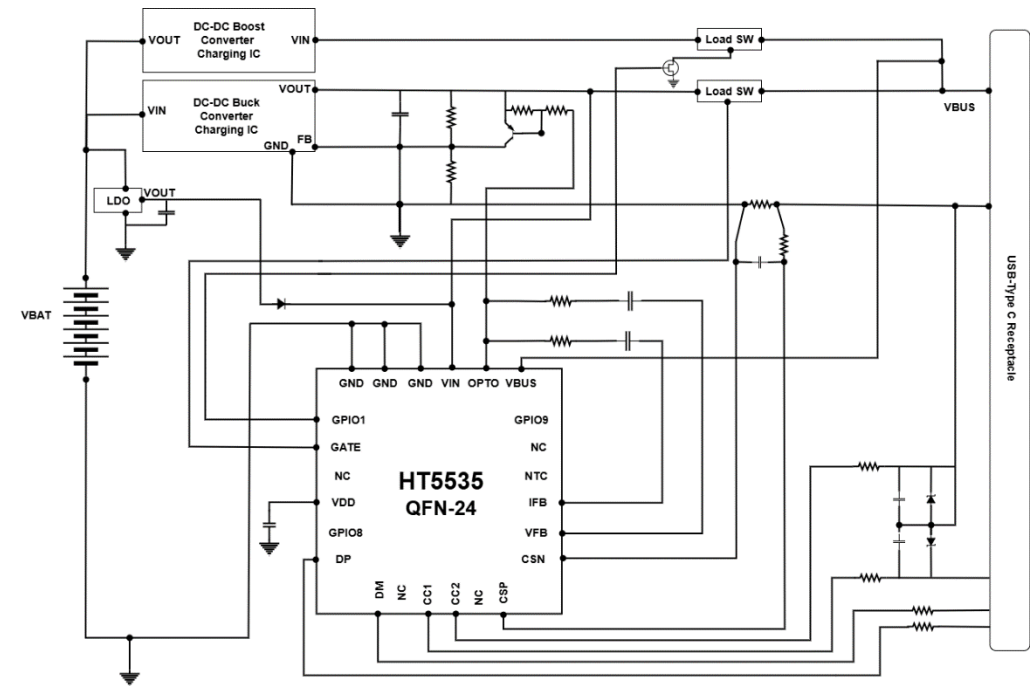

Typical Application Circuit of HT5535

DC-DC Green Power IC Series

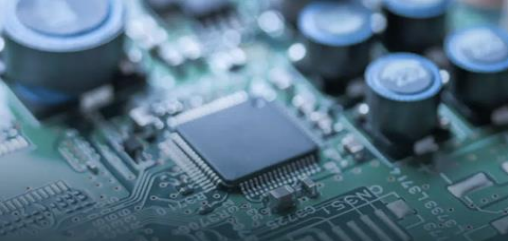

 Power management	HTT Green Power IC Series		
	HT3000 Series HT6000 Series (External FET)	HT7000 Series (Internal FET)	HT6329S (Multiphase)
IC Output Channels	2	2	1
Input Voltage	5V to 36V	5V to 36V	5V to 36V
Output Voltage	3V to 21V	3V to 12V	3V to 21V
Output Current	3A to 6A	3A per channel	3~40A or larger
Switching Frequency	300k/500k/700kHz	333k~1MHz	300k/500k/700kHz
Unique Feature	Cool thermal performance	Efficient and small	Powers AI edge devices



Multi-phase DC-DC, 3.3V-40A Application

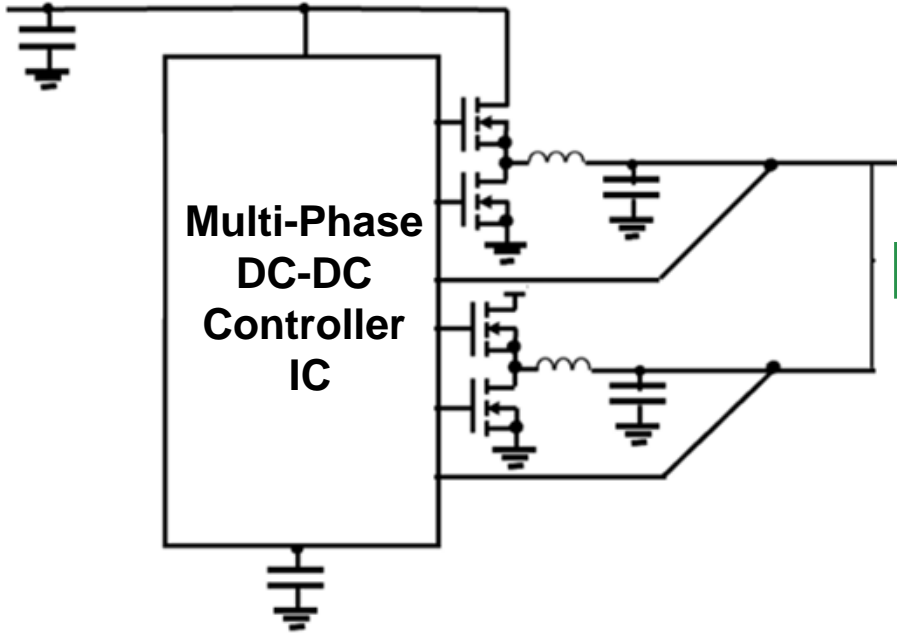

EV Dash-Board
EV-CPU



T4 GPU



HT6329S: Multi-phase DC-DC Buck Converter 3.3V-40A

HT6329S - High-Efficiency, Small Inductor, Multiphase 36V Dual-Buck DC-DC Controller with max. 700kHz for 3.3V-40A application

FEATURES

Dual-Channel Synchronous Buck Controller

- Wide input voltage range: 4.7V to 36V
- Dual Channel with independent input voltage
- Dual channel or single-output multiphase
- Multiphase mode may have output up to 3.3V, 45A current in typical cases.
- Independent external feedback for each channel
- Selectable switching frequency at 300kHz, 500kHz and 700kHz
- Support Constant Current (CC) / Constant Voltage (CV) mode
- Soft start

Multi-Protection

- Input under-voltage lockout (UVLO)
- Output over-voltage protection (OVP)
- Output short-circuit protection (SCP)
- Over-temperature protection (OTP)

APPLICATION

- Low-EMI Applications (Patented dithering technique)
- Automotive ADAS Power Supply
- CPU Power supply for NVIDIA/Qualcomm-like AI-Chipsets, in multi-phase operations
- USB Type C PD3.1 and Type A QC3.0 Fast Charging Application for dual-buck mode operations
- Automotive LED Lighting
- LCD / TV / Monitor Power

DEVICE INFORMATION

Part Number	Package	Dimensions (mm)
HT6329S	WQFN32	5.0 x 5.0 x 0.75

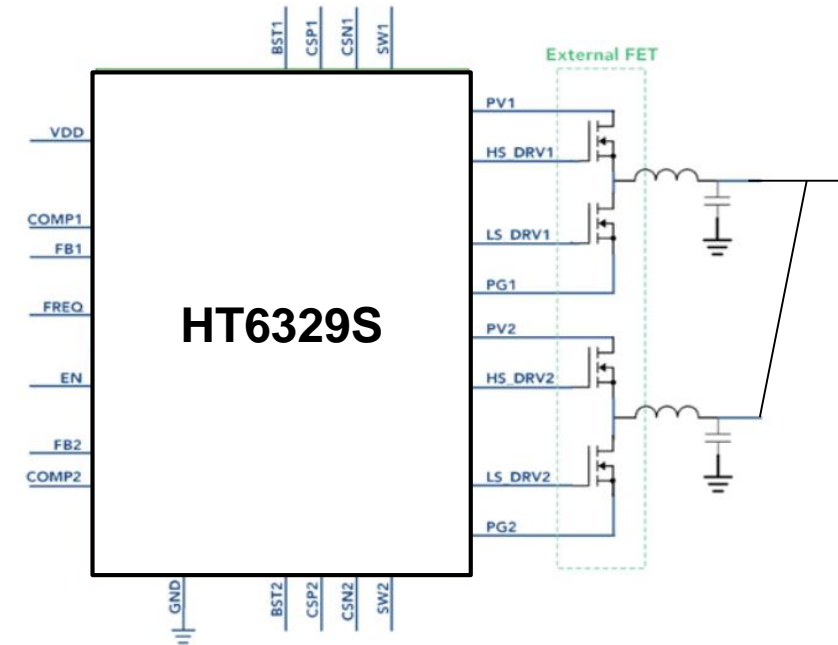

Typical Application Circuit of HT6329S



HT7228P: Integrated-FET DC-DC Buck Converter High-Frequency-Power, Small-Size

HT7228P – 36V, 1MHz max, Dual 3.6A Synchronous Buck Converter with Low EMI and High Efficiency

FEATURES

Dual-Channel Synchronous Buck converter

- Low $R_{DS(ON)}$ internal power MOSFET 100m Ω /100m Ω
- Wide input voltage range: 4.7V to 36V
- Output current up to 3.6A at each channel
- Independent external feedback for each channel
- Adjustable switching frequency from 350kHz to 1MHz
- Support Constant Current (CC) / Constant Voltage (CV) mode
- Combine mode for higher output power applications
- Soft start
- 20 μ A typical shutdown current

Multi-Protection

- Input under-voltage lockout (UVLO)
- Output over-voltage protection (OVP)
- Output short-circuit protection (SCP)
- Over-temperature protection (OTP)

APPLICATION

- USB Type C PD3.1 and Type A QC3.0 fast charging supply
- Low-EMI Applications (Patented dithering technique)
- Automotive ADAS Power Supply
- Automotive LED Lighting
- LCD / TV / Monitor Power
- Low EMI Application (*Patent Pending*)
- Combine-mode, support single-channel, higher power (*Patent Pending*)

Device Information

Part Number	Package	Dimensions (mm)
HT7228P	WQFN32	5.0 x 5.0 x 0.75

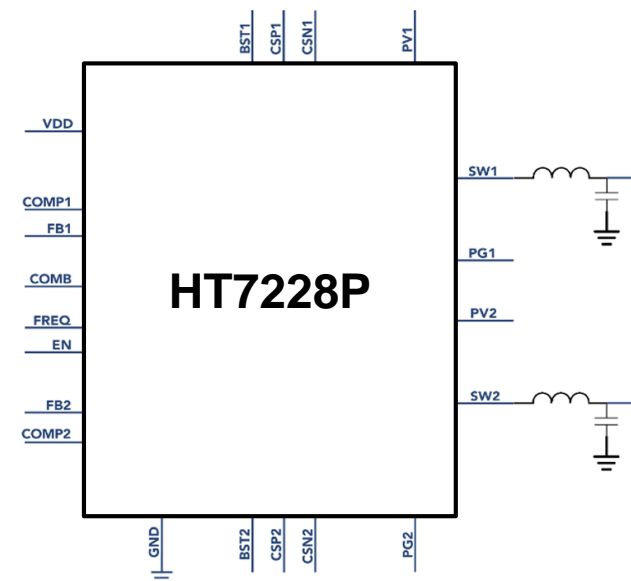

Typical Application Circuit of HT7228P

HT3328S: External FET DC-DC Buck Converter

HT3328S – High-Efficiency, IoT-Enabled, External MOSFET

Dual-Buck DC-DC Controller with Selectable frequency up to

700kHz

FEATURES

Internet of Things (IoT) Enable function

- ON/OFF control
- Programmable using I²C serial interface
- Wireless connection with mobile apps

A sample IoT function is illustrated below flowchart:



Multi-Protection

- Input under-voltage lockout (UVLO)
- Output over-voltage protection (OVP)
- Output short-circuit protection (SCP)
- Over-temperature protection (OTP)

APPLICATION

- IoT (Internet of Things) Smart Home Appliance
- Mobile apps controllable DC source
- Automotive ADAS/LED Power Supply
- LCD Monitor Power Supply
- Wireless Router Power Supply
- Remote Power Management
 - Power Scheduler
 - CC-CV
- Low EMI Application (Patent Pending)

Device Information

Part Number	Package	Dimensions (mm)
HT3328S	WQFN32	5.0 x 5.0 x 0.75

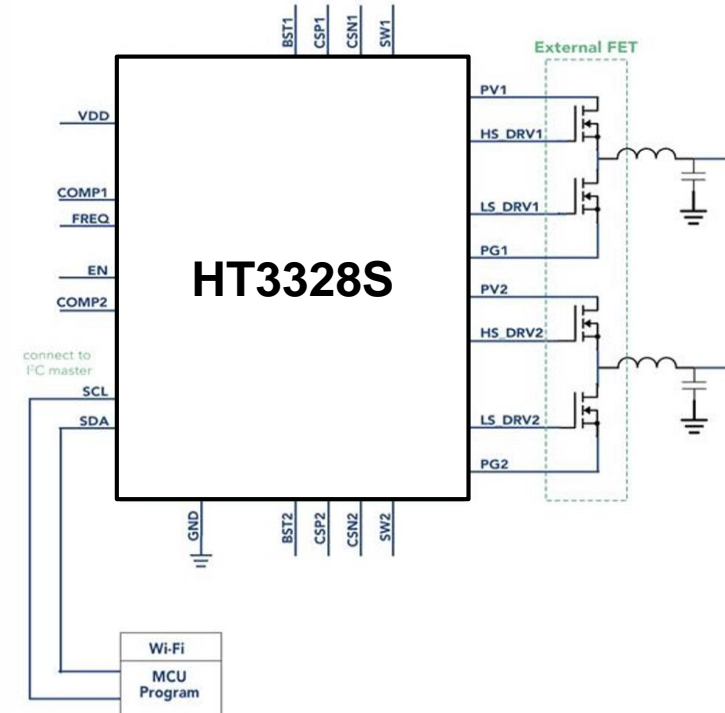

Typical Application Circuit of HT3328S

HT6122S: External FET DC-DC Buck Converter

HT6122S – High Efficiency, Dual Buck DC-DC Controller with Internal Protocol, Selectable Switching Frequency up to 700kHz

FEATURES

Dual-Channel Synchronous Buck Controller

- Wide input voltage range: 4.7V to 36V
- Output current up to 3.6A, or higher
- One channel built in QC Protocol, reducing BOM
- External feedback for another channel
- Dual Channel Fast Charging simultaneously
- Selectable switching frequency at 300kHz, 500kHz and 700kHz
- Support CC / CV mode
- Soft start

Multi-Protection

- Input under-voltage lockout (UVLO)
- Output over-voltage protection (OVP)
- Output short-circuit protection (SCP)
- Over-temperature protection (OTP)

APPLICATION

- USB Type-C/Type-A fast charging applications
- LCD monitor/TV
- Desktop PC
- Automotive ADAS Power
- Low EMI Application (Patented dithering technique)

DEVICE INFORMATION

Part Number	Package	Dimensions (mm)
HT6122S	WQFN32	5.0 x 5.0 x 0.75

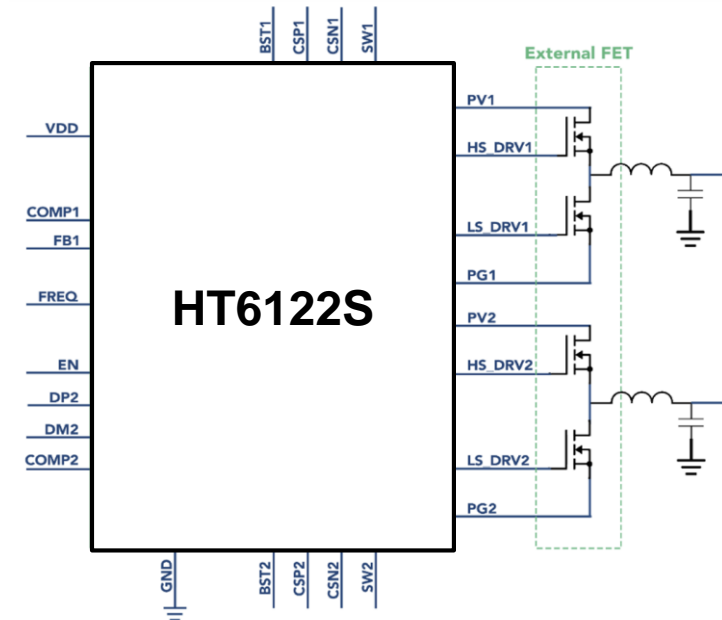

Typical Application Circuit of HT6122S

HT1388: Automotive Lighting Solution

33-Channel RGB LED Driver with Internal FET



芯高科技
HIGH TECH
TECHNOLOGY LIMITED

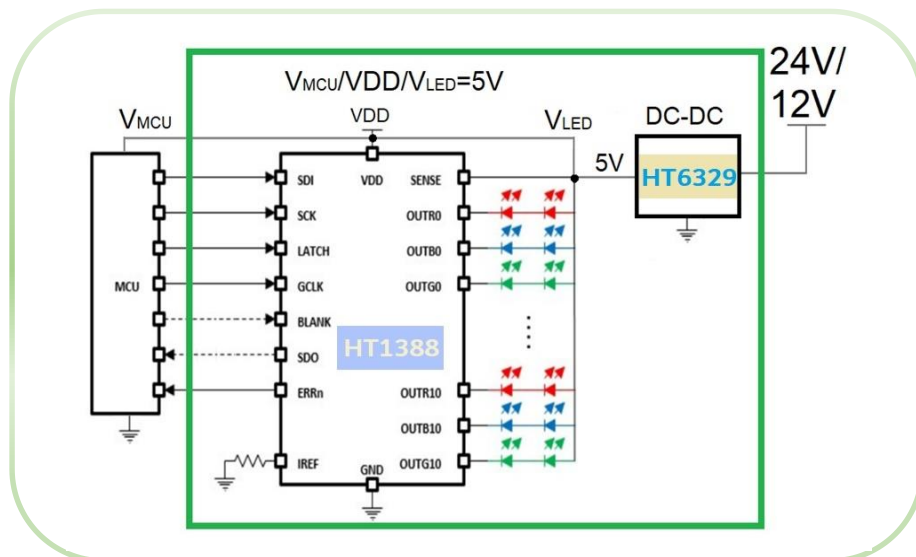

Product Application

- Headlights & turn signals
- Dashboard & interior lighting
- Smart ambient & beat-sync effects
- Hi-Fi & decorative lighting
- IoT remote light control
- ...





HT1388: RGB LED Driver IC

High Accuracy, Full Protection & Diagnostics, Constant-Current RGB LED Driver with Sleep-Mode

1. FEATURES

- 33 Constant-Current-Sink Output Channels
 - 30-mA Maximum Output Current
 - 5-V Maximum Output Voltage
 - 3 Output Groups: OUTRn, OUTGn, OUTBn
- Output Current Adjustment
 - 7-Bit Dot Correction for Each Channel
 - 8-Bit Intensity Control for Each Group
- Integrated PWM Grayscale Generator
 - PWM Dimming for Each Individual Channel
 - Adjustable Global Grayscale Mode: 12-Bit, 10-Bit, 8-Bit
- Protection and Diagnostics
 - LED-Open Detection, LED-Short Detection, Output Short-to-GND Detection
 - Adjacent-Pin Short Detection
 - Pre-Thermal Warning, Thermal Shutdown
 - IREF Resistor Open- and Short-Detection and -Protection
 - Negate Bit Toggle for GCLK Error Detect and LOD_LSD Register Error Check
 - LOS_LSF Circuit Self-Test
- Programmable Output Slew Rate
- Output Channel Group Delay
- Support Serial Data Interface Communication from Simple 8-bit MCU
- Support Sleep Mode with supply current below 100uA
- High Accuracy: Typical +/-7% per channel

2. APPLICATIONS

- Automotive Interior & RGB Ambient Lighting
- Automotive Center Stack Display
- Automotive Shift-by-Wire and Gear Shifter
- Automotive Faceplate
- Automotive Local Dimming Display

3. GENERAL DESCRIPTION

The HT1388 is designed for driving 33-channel LEDs Driver. It can supply a maximum 30mA constant output current set by an external resistor. The device has a 7-bit dot correction for each output. The device also has an 8-bit intensity control for the outputs of each color group.

A 12-, 10-, or 8-bit grayscale control adjusts the intensity of each output. The device has circuits that sense faults in the system, including LED faults, adjacent-pin short faults, reference-resistor faults, and etc. Two slew rate control can be programmed for adjustment to get the largest decrease in system noise. There is an interval between the changes of output level from on LED group to a different one. This interval helps to decrease the starting electrical current. The SDI and SDO pins let more than one device be connected in series for control through one serial interface.

4. PART NUMBER INFORMATION

PART NO.	PACKAGE
HT1388FP	eQFP48
HT1388FN	QFN48

5. TYPICAL APPLICATION

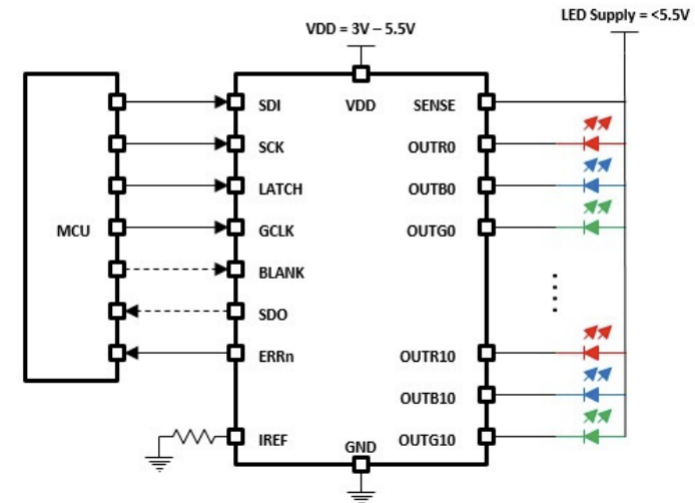

Typical Application Circuit

Behind Every End Product — Powerful Module

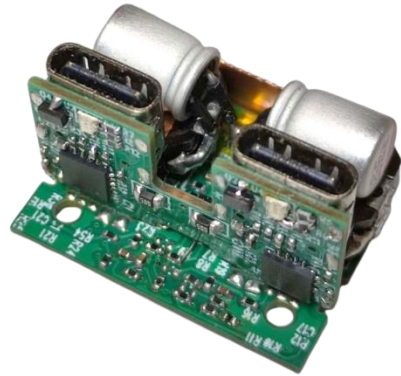

65W dual USB Type-C module

Input voltage	24Vdc
Single port output	5V 3A, 9V 3A, 12V 3A, 15V 3A, 20V 3.25A
Dual port output 1	5V 3A, 9V 3A, 12V 3A, 15V 3A
Dual port output 2	5V 3A, 9V 3A
Maximum power	65W



30W Dual USB Type-C module

Input voltage	200V~240V 50/60Hz
Single port output	5V 3A, 9V 3A, 12V 2.5A, 15V 2A, 20V 1.5A
Dual port output 1	5V 3A, 9V 1.5A
Dual port output 2	5V 3A, 9V 1.5A
Maximum power	30W

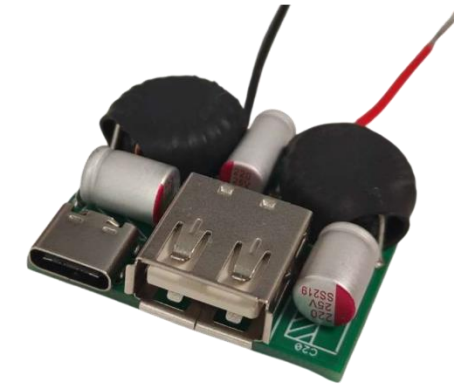

USB Solution for Automotives

Input voltage	7-20Vdc
Output voltage	5.2V
Output current	3A per channel 6A total output
Output Power	30W
Efficiency	>95%

These are sample modules — we offer a wide range of custom and standard solutions.

Typical End-Product Solutions



Fast Charger



Wall Socket



Car Charger



AI Camera

and more...



Contact Us



Website: www.hightt.com

Email: admin2@hightt.com

Phone: +852 3619 5375

Address: Unit 713, 7/F, 12W, 12 Science Park West Avenue,
Hong Kong Science Park, Shatin, NT, Hong Kong